

Engine Control <2AD-FTV>

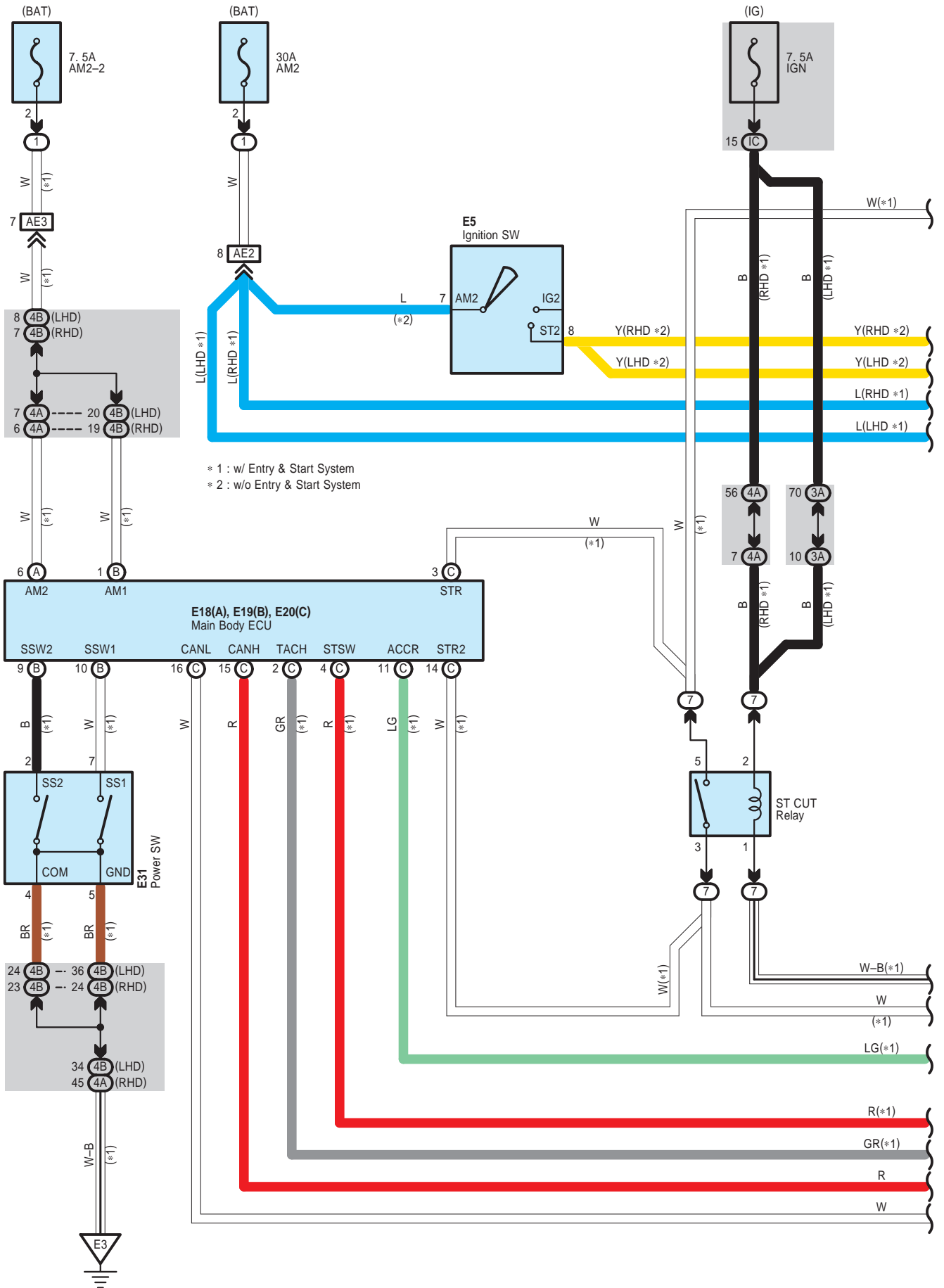

Engine Control <2AD-FTV>

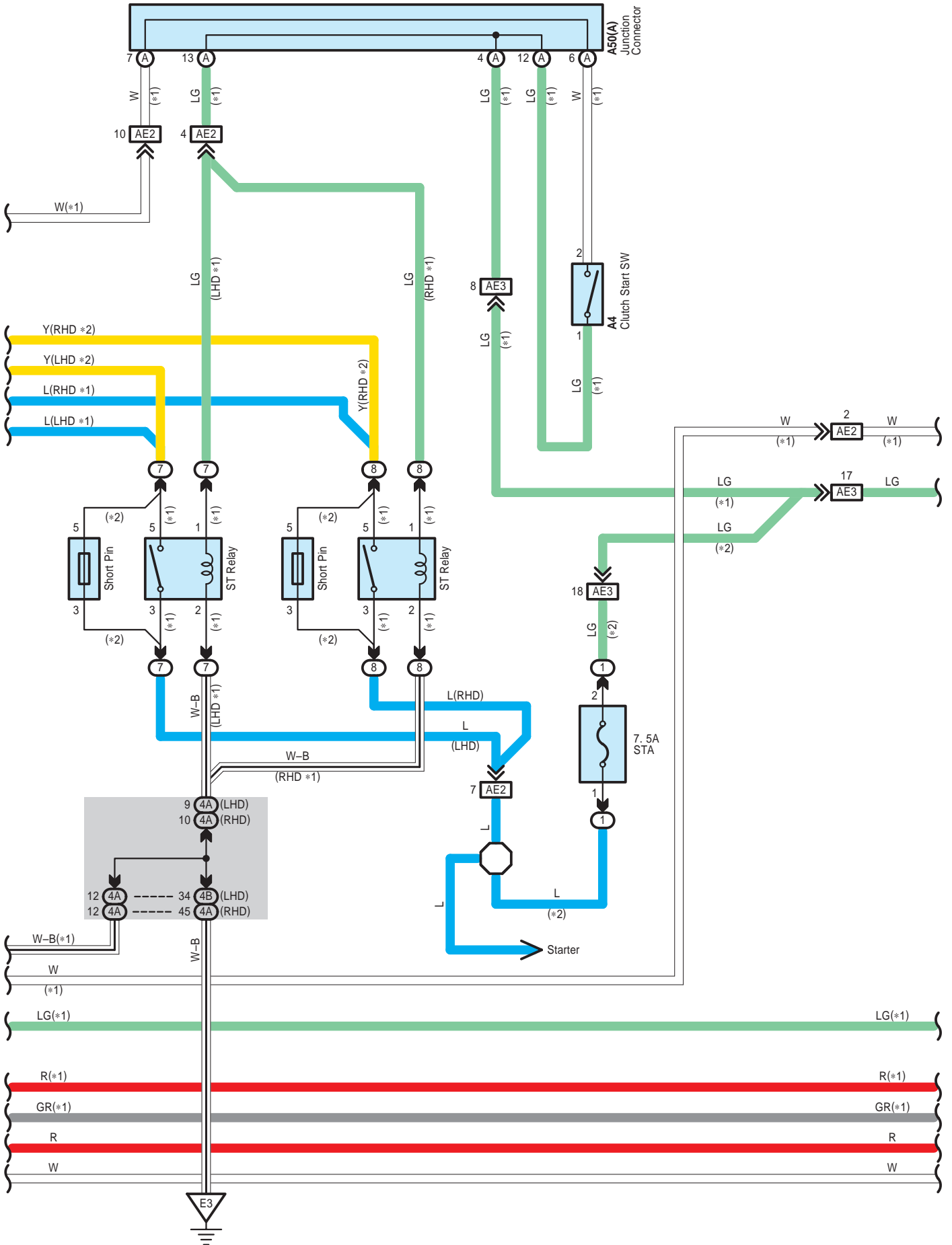

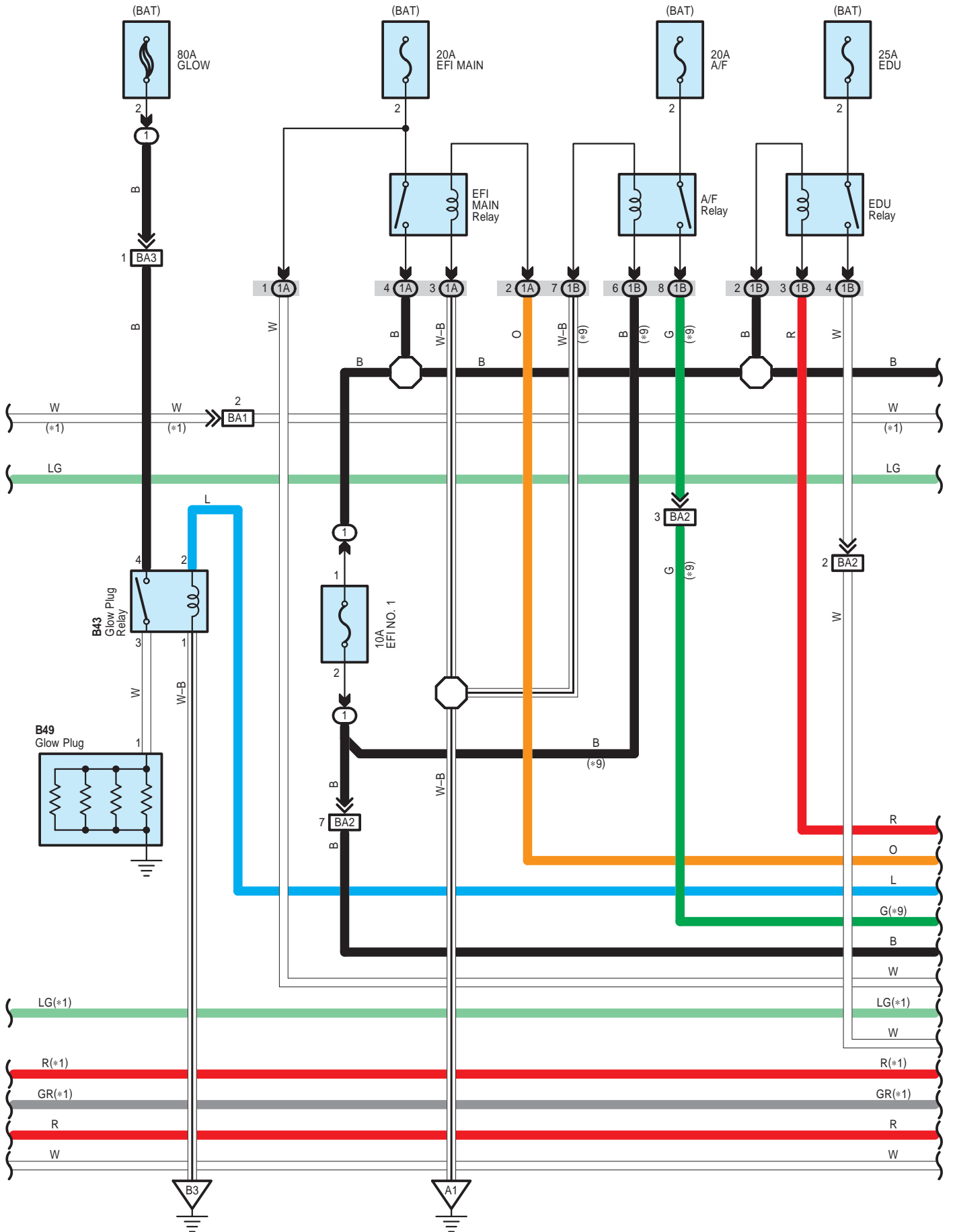

Engine Control <2AD-FTV>

* 1 : w/ Entry & Start System
 * 9 : w/ DPF

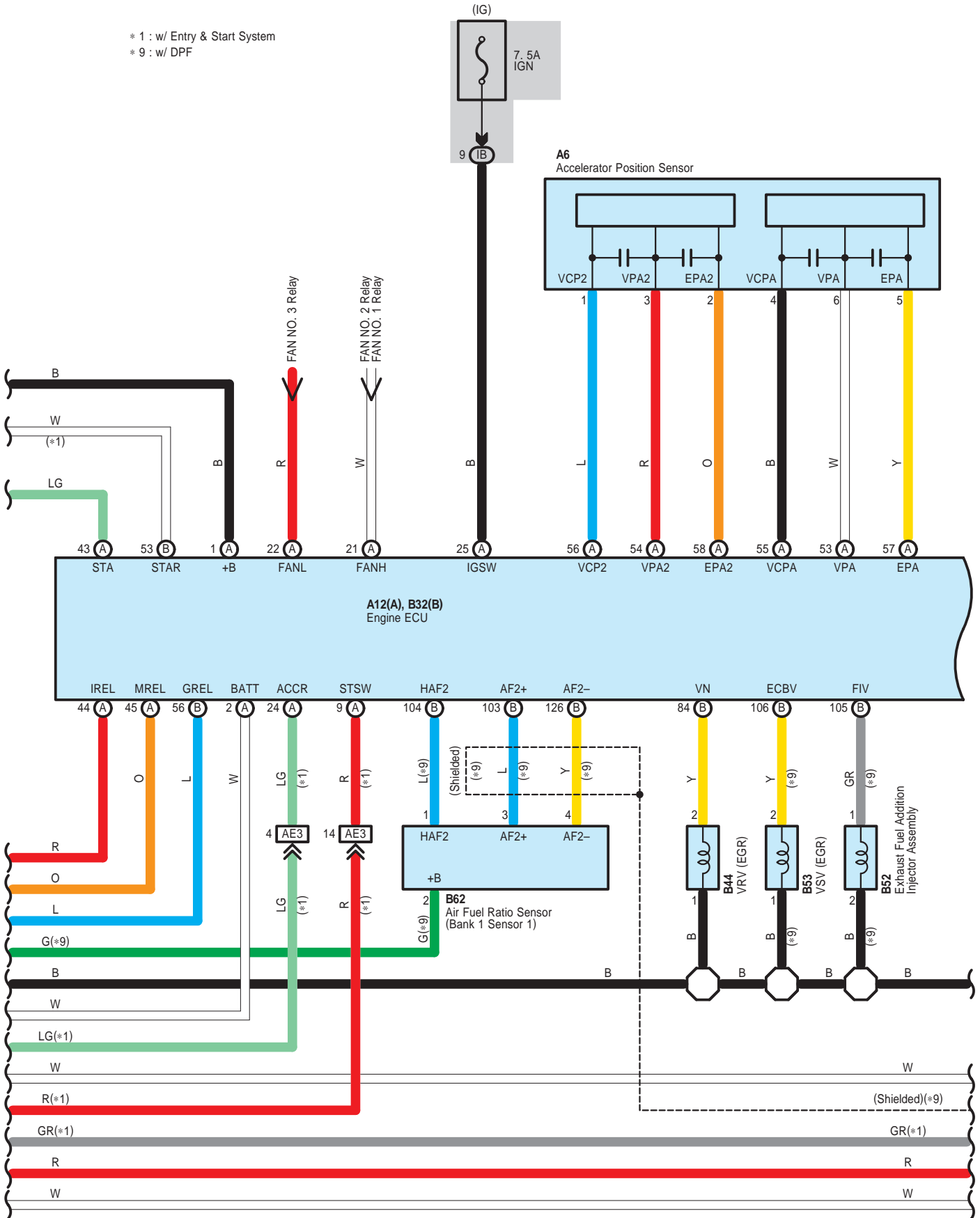

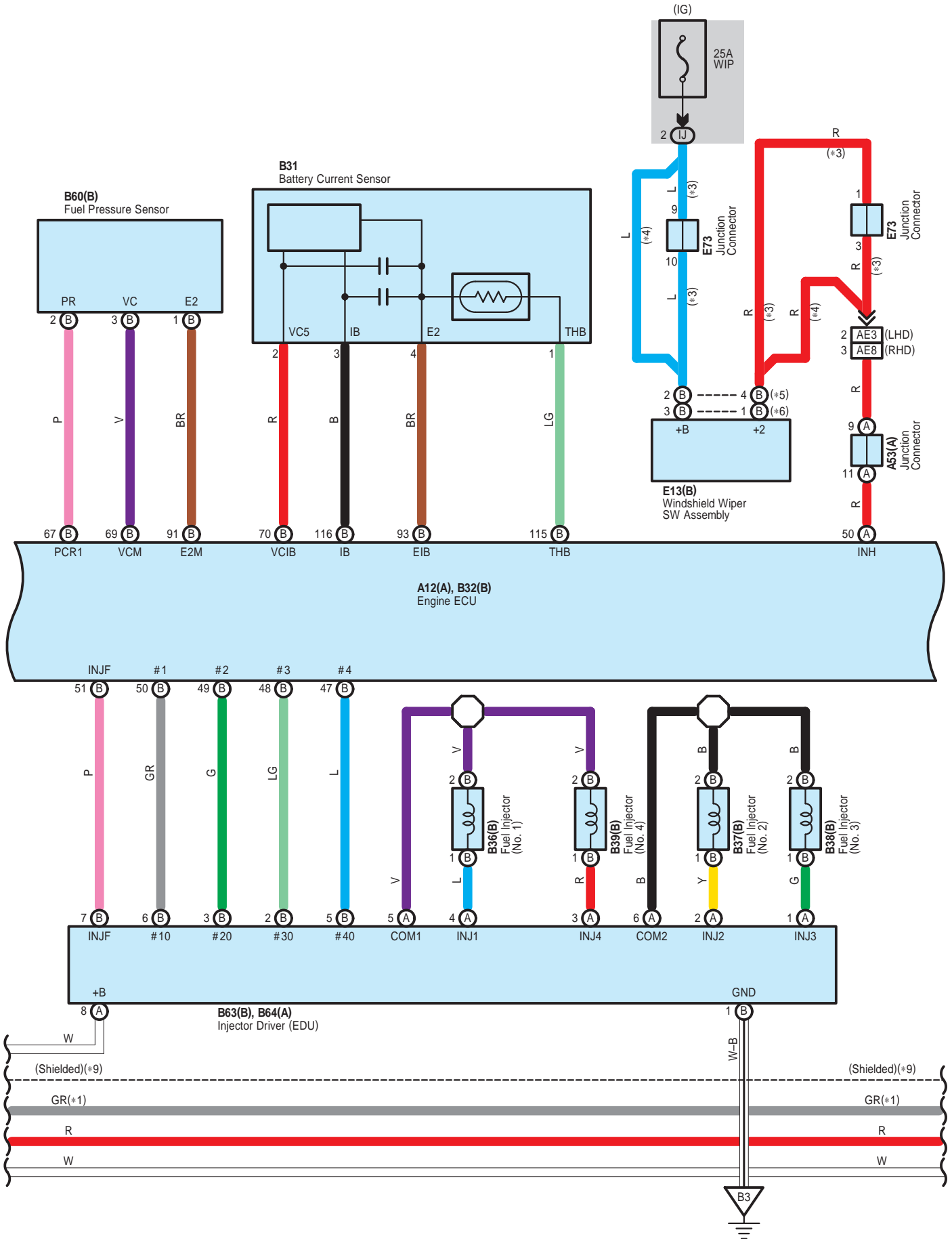

- * 1 : w/ Entry & Start System
- * 2 : w/o Entry & Start System
- * 7 : w/ VSC
- * 8 : w/o VSC
- * 9 : w/ DPF

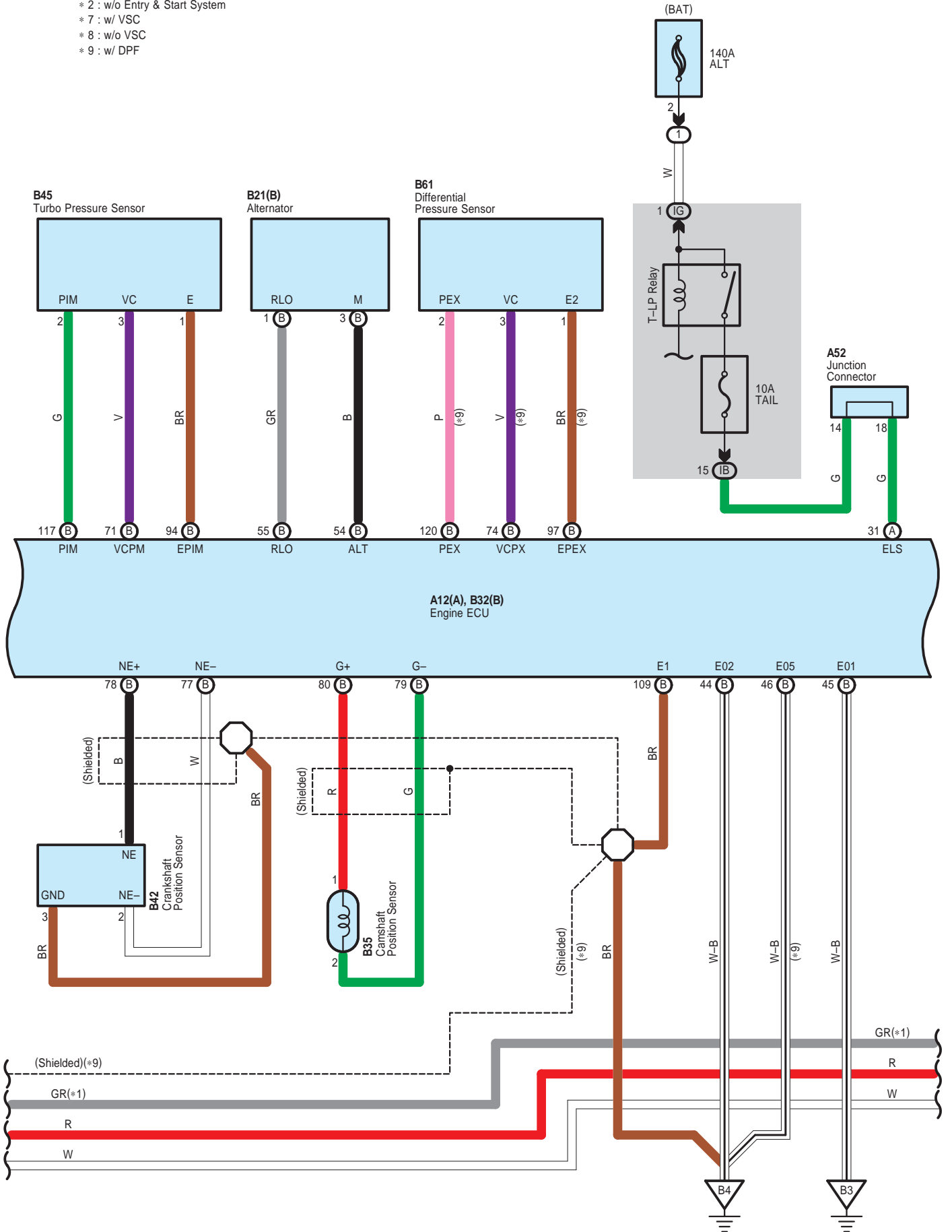

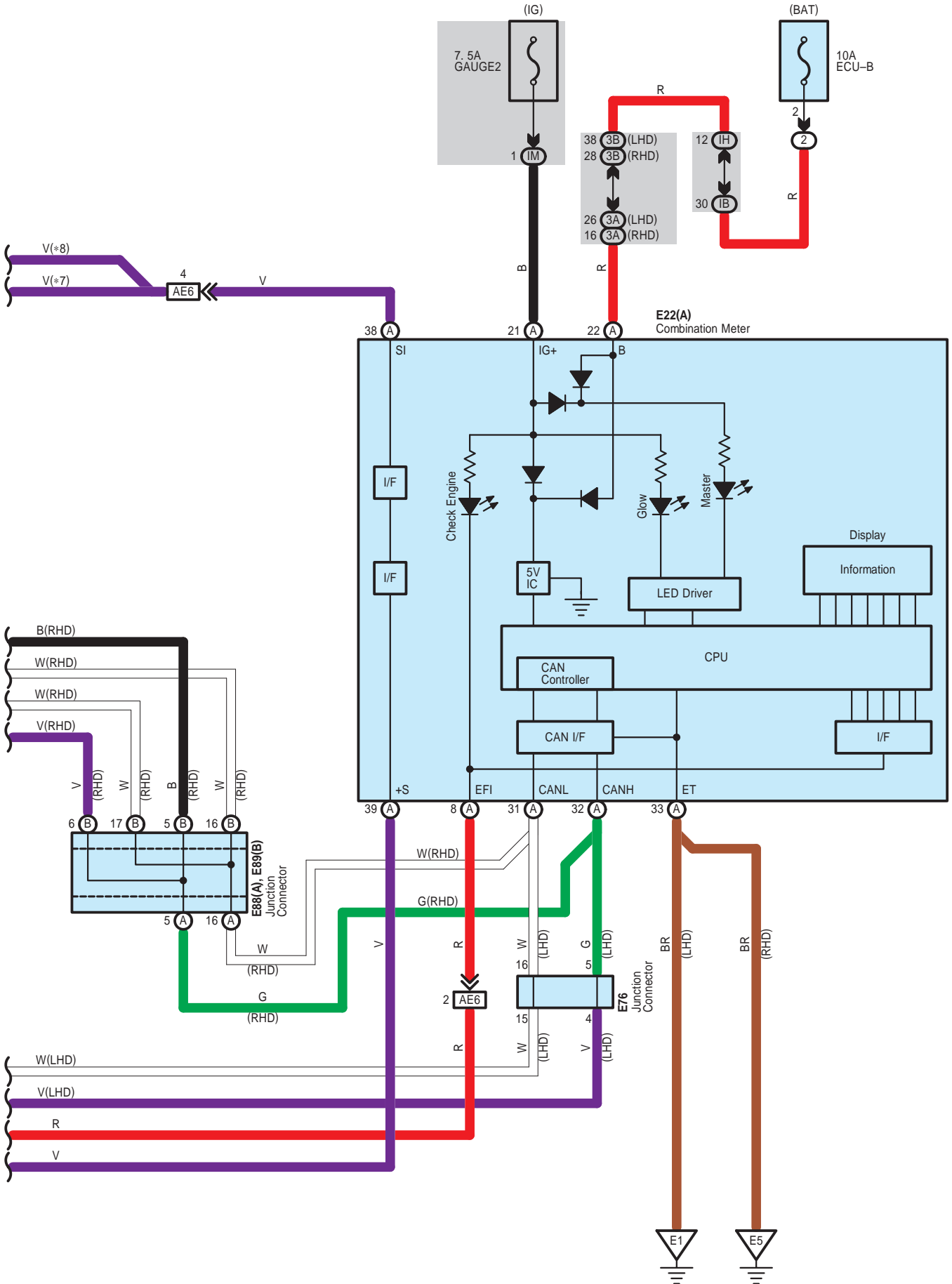

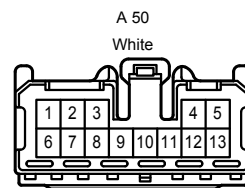
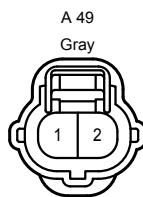
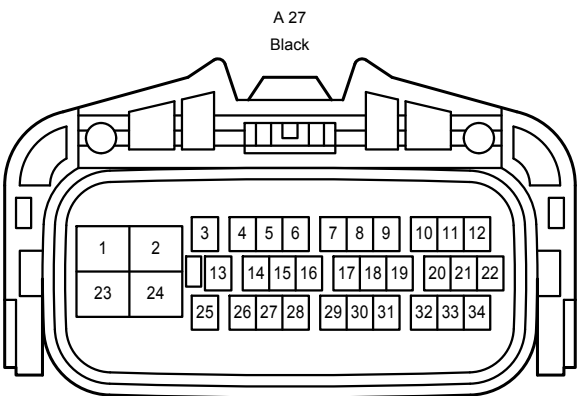
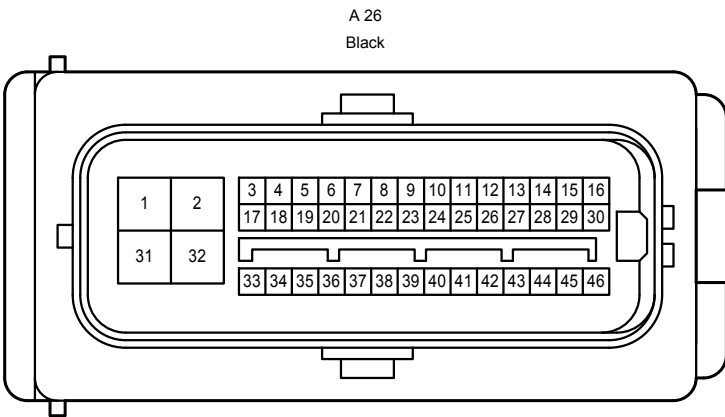
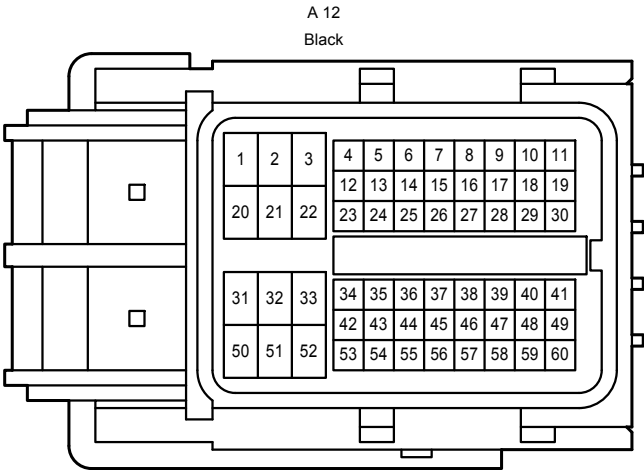
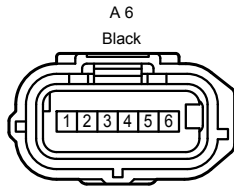
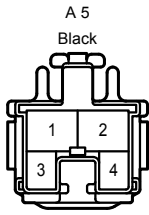
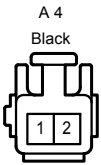

Engine Control <2AD-FTV>

B 54
Black

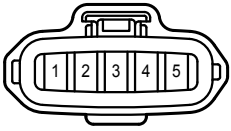

B 55
Black



B 56
Gray



B 57
Dark Gray



B 60
Black



(2AD-FTV)

B 61
Black

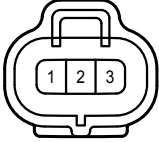

B 62
Dark Gray



B 63
Dark Gray

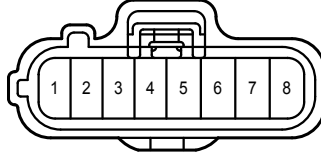

B 64
Black

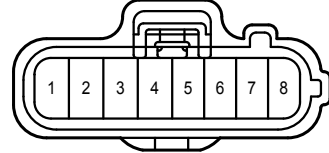

E 5
White

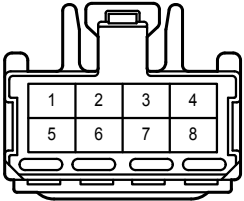

E 13
White

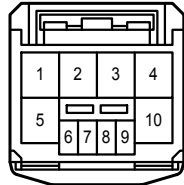

E 16
White

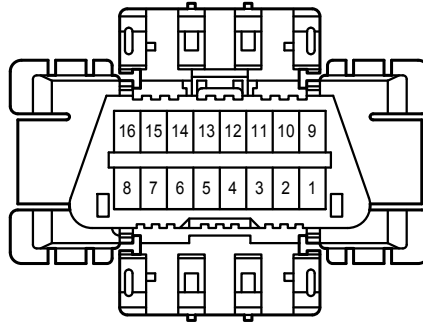

E 18
White

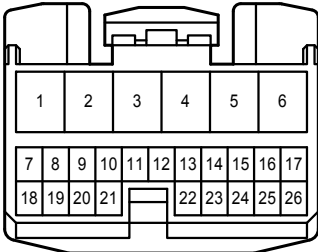

E 19
White

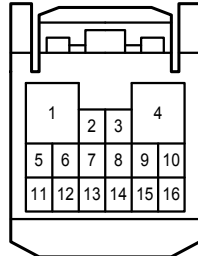

E 20
White

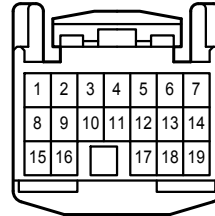

E 22
White

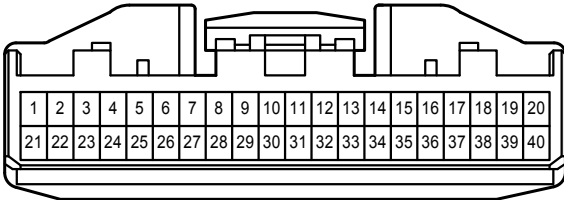

E 31
Black

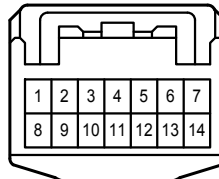

E 50
White

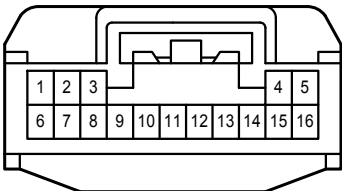

(Before Aug. 2010 Production)

E 50
Black

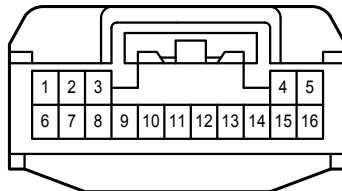

(From Aug. 2010 Production)

E 51
White

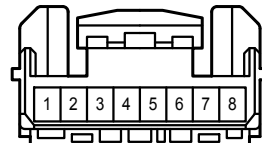

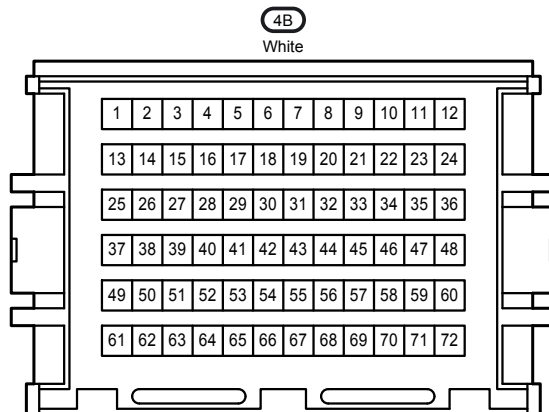
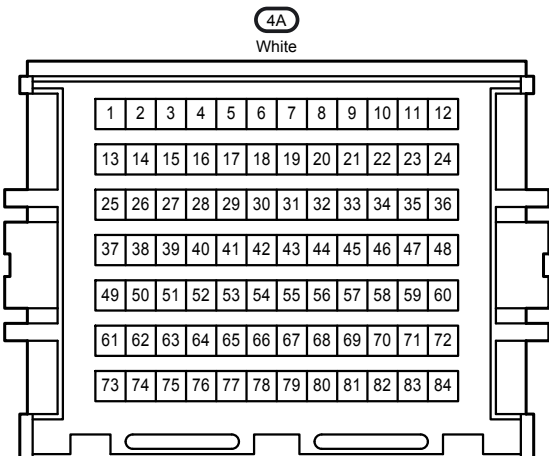
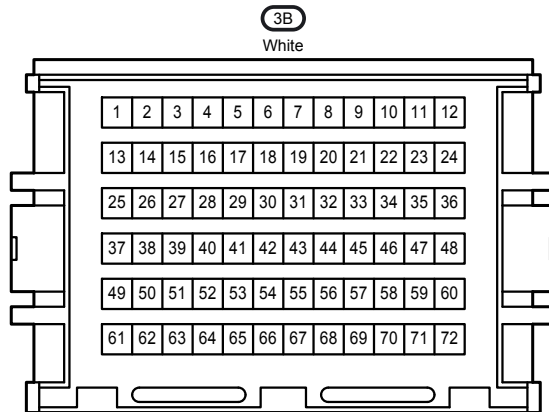
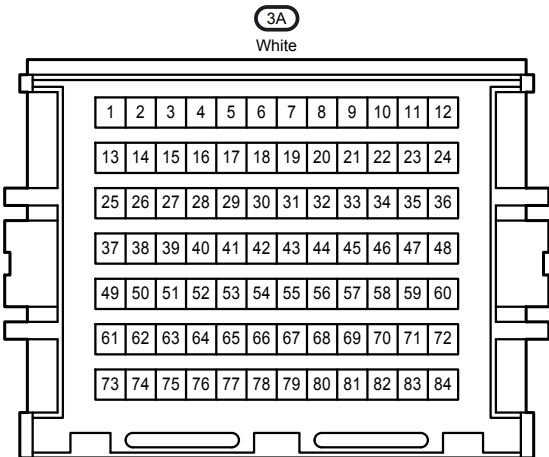
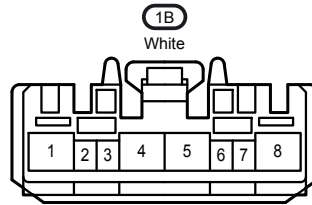
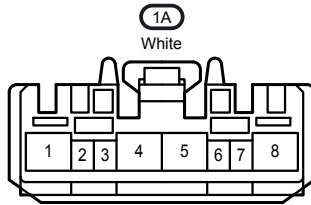
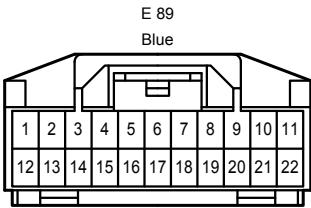
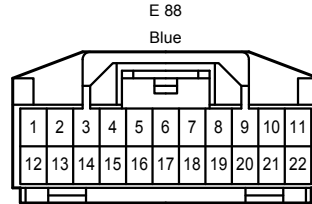
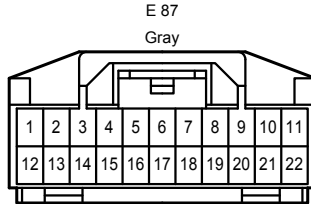
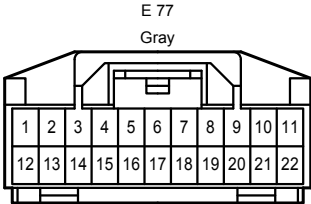
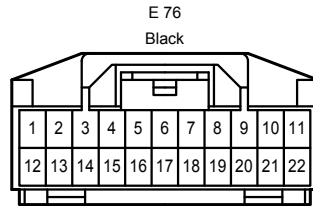
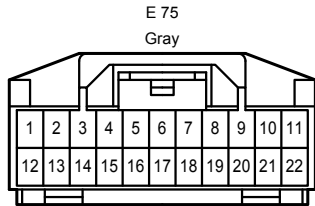
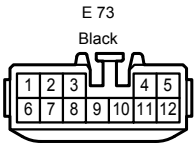

IB
White

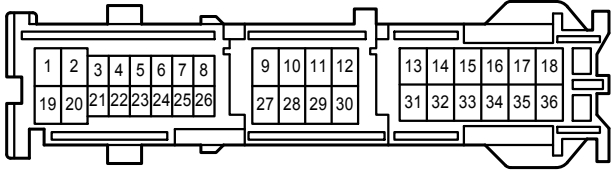

IC
White

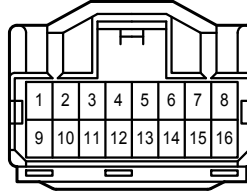

ID
White

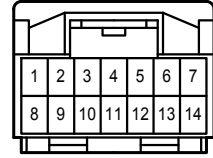

IG
White

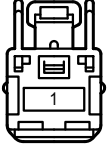

IH
White

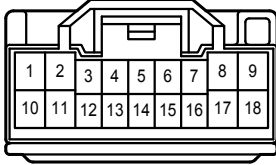

IJ
White

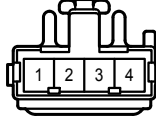

IM
White

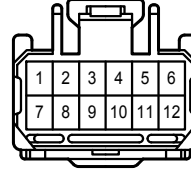

AE1
White

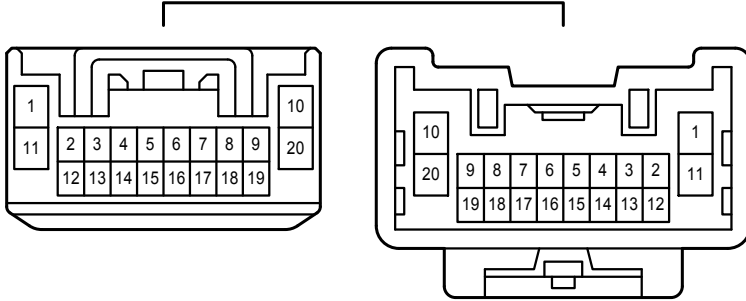

AE2
White

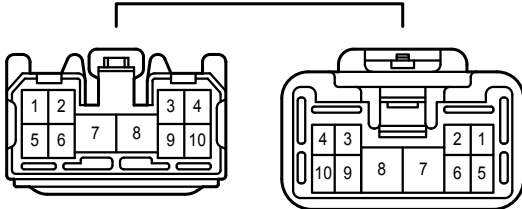

AE3
Black

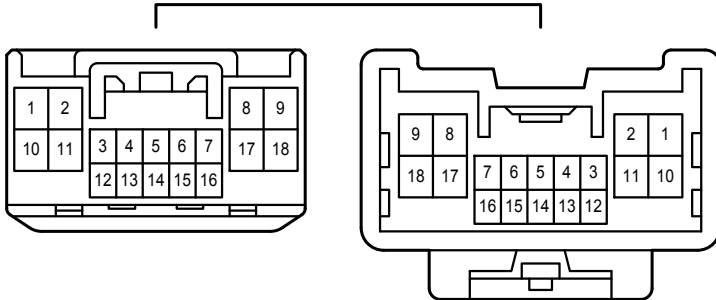

AE4
Gray

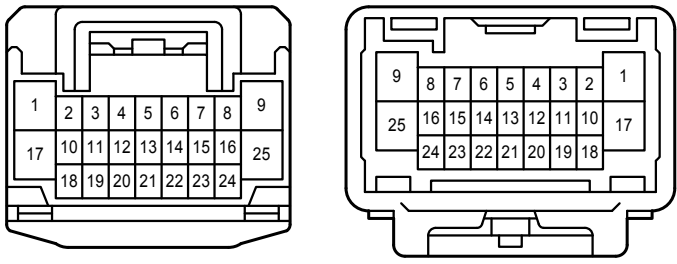

AE6
White

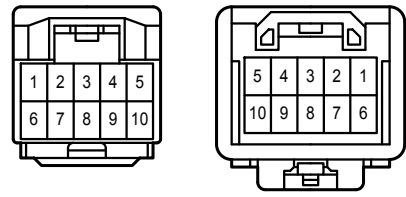

AE8
White

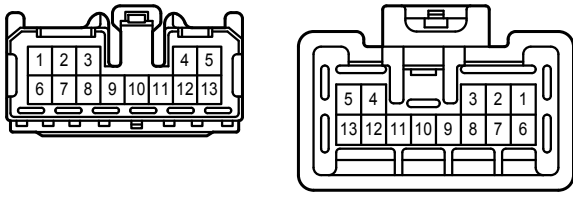

BA1
White

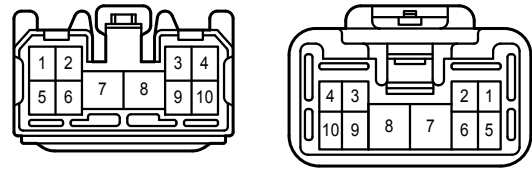

BA2
Gray

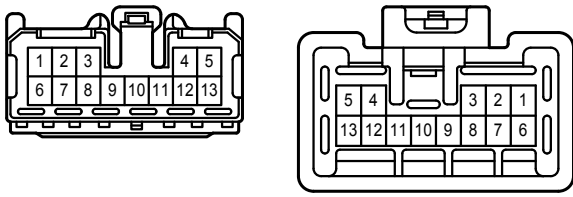

BA3
White

