

# Engine Control <3ZR-FAE>

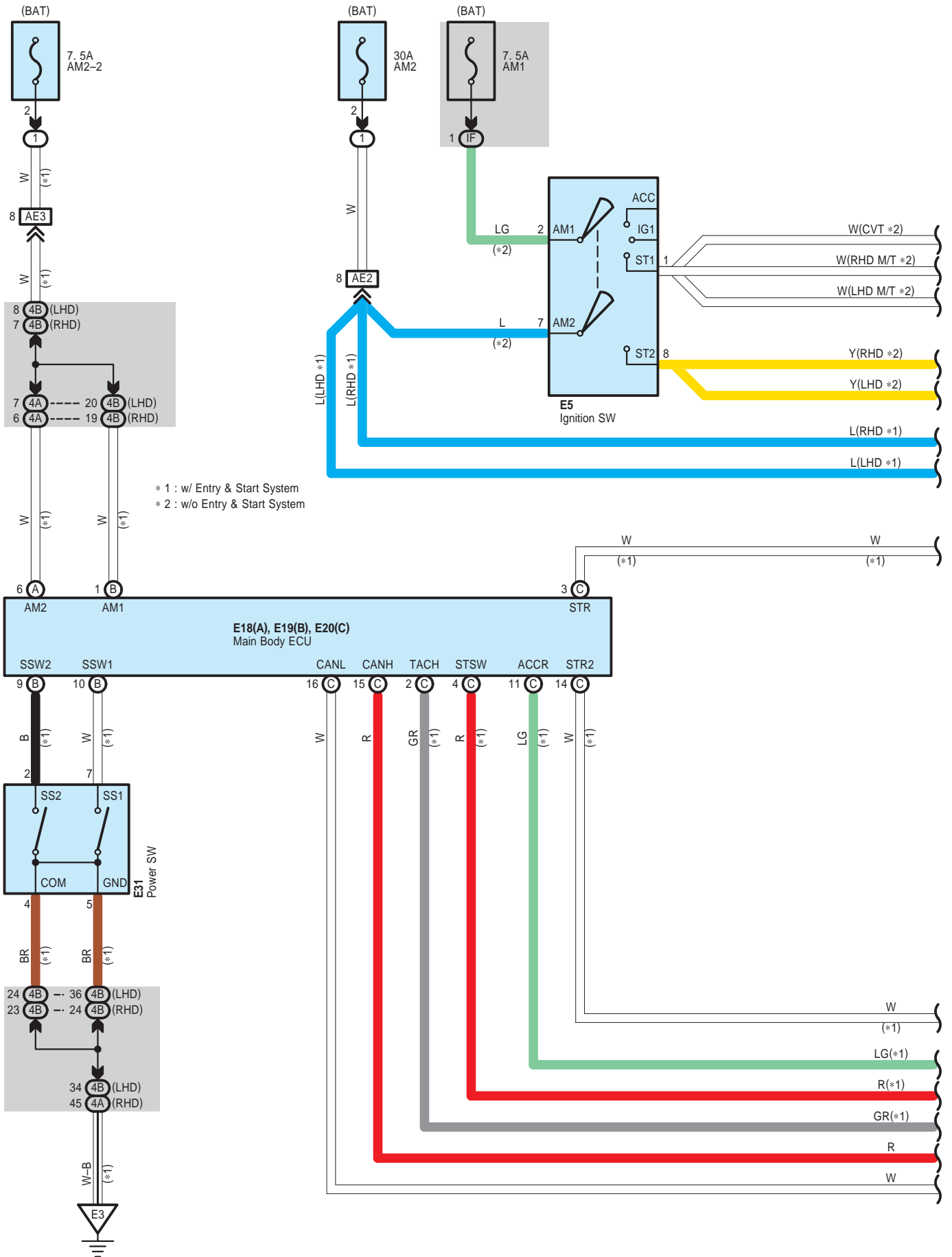

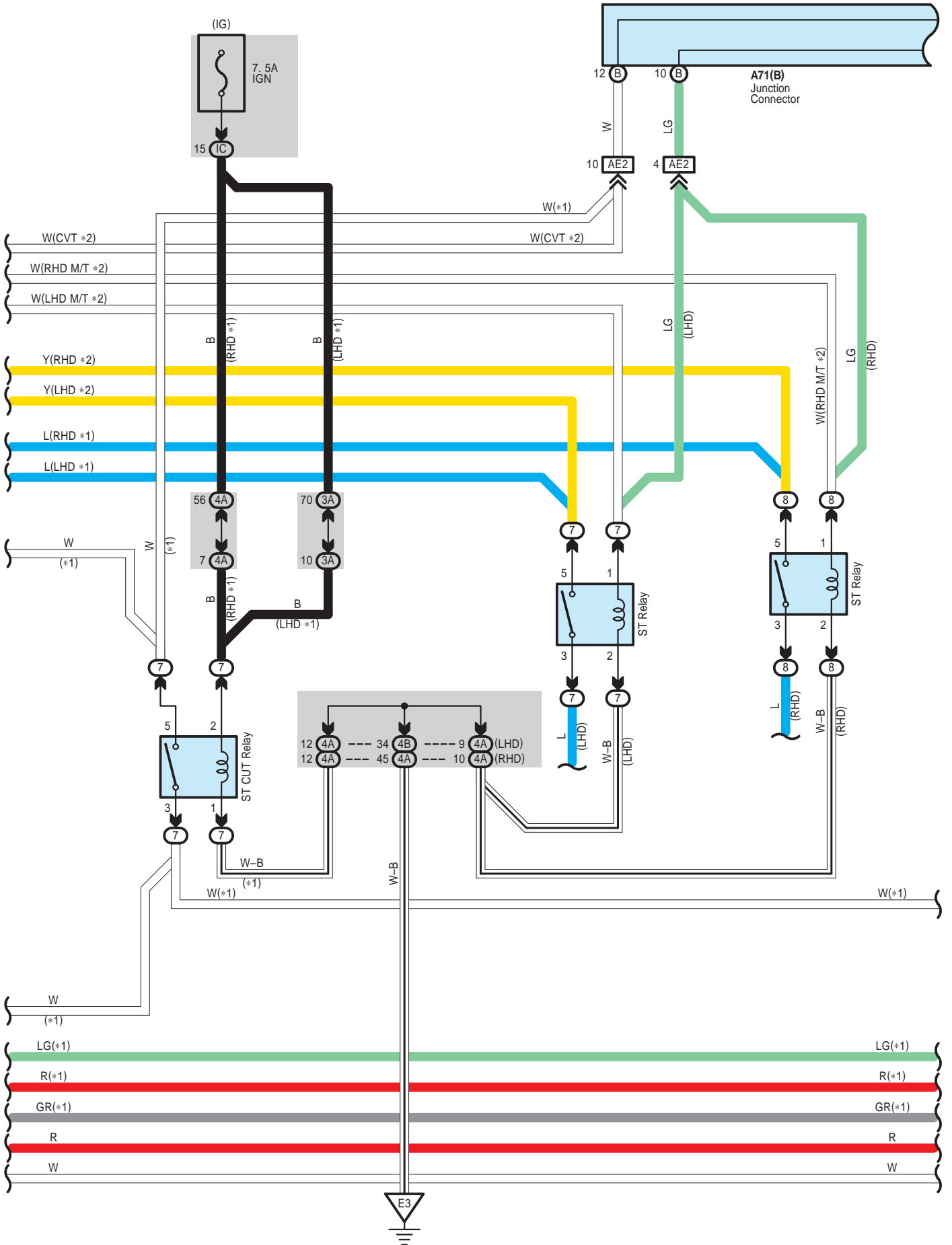

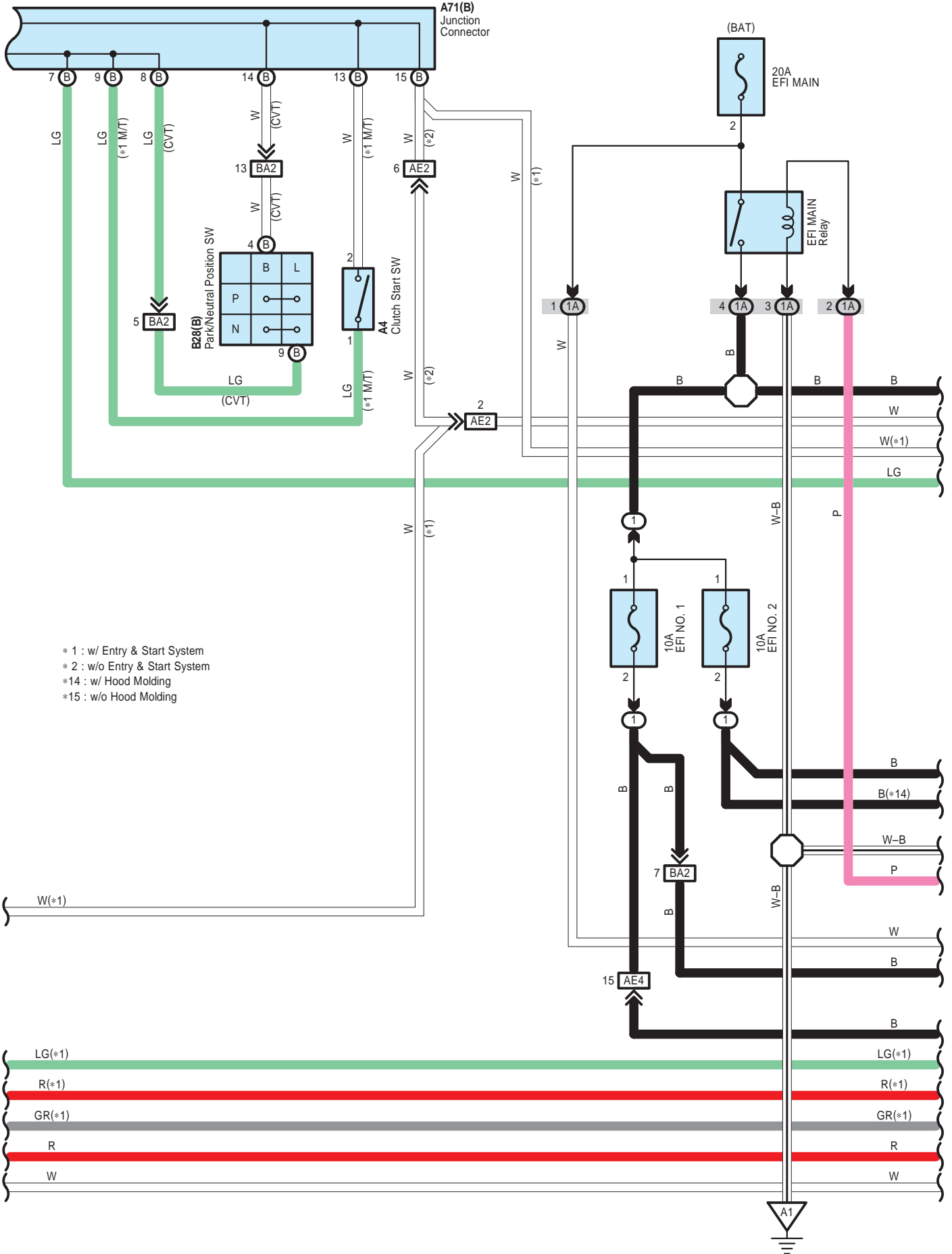

- \* 1 : w/ Entry & Start System
- \* 2 : w/o Entry & Start System
- \* 14 : w/ Hood Molding
- \* 15 : w/o Hood Molding

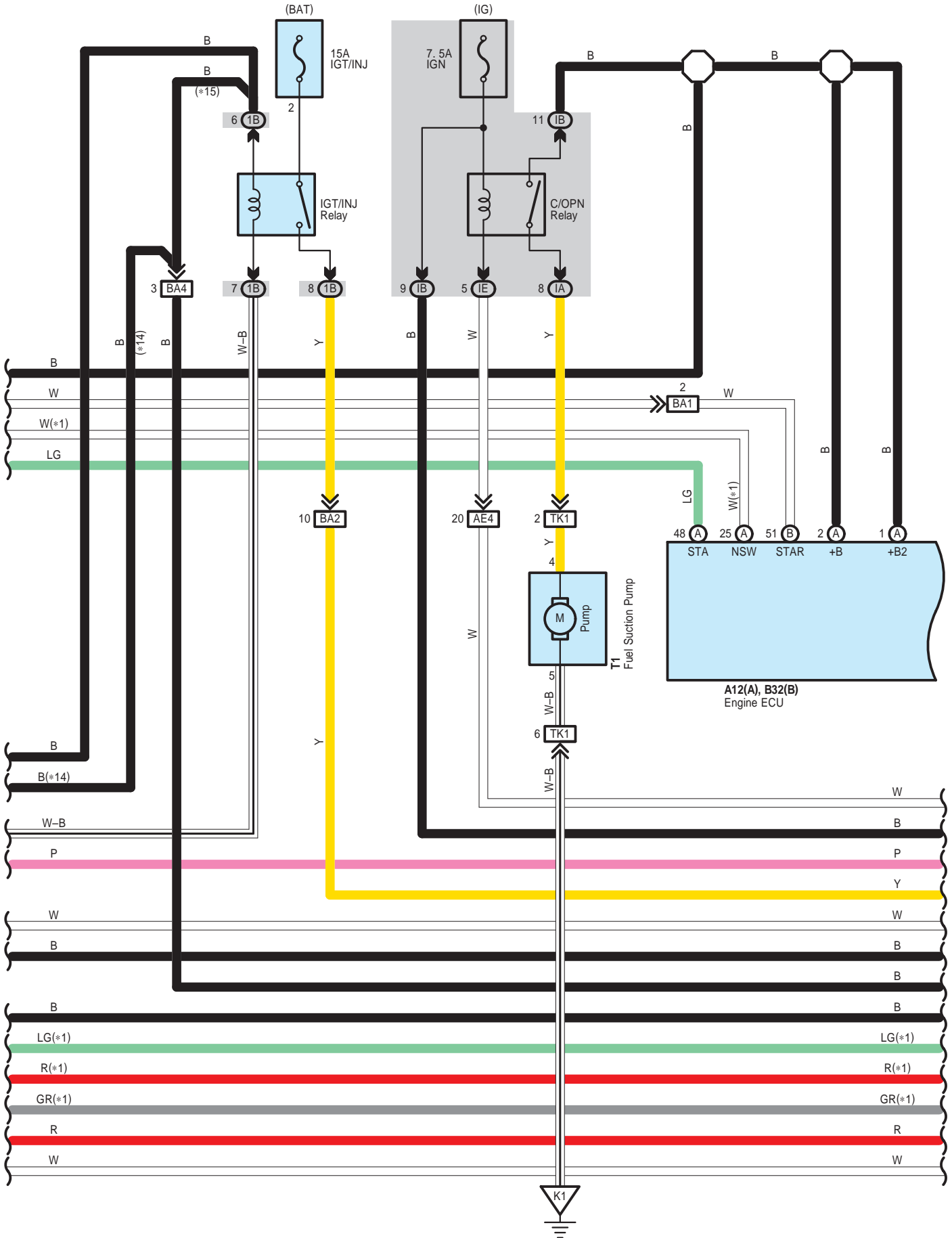

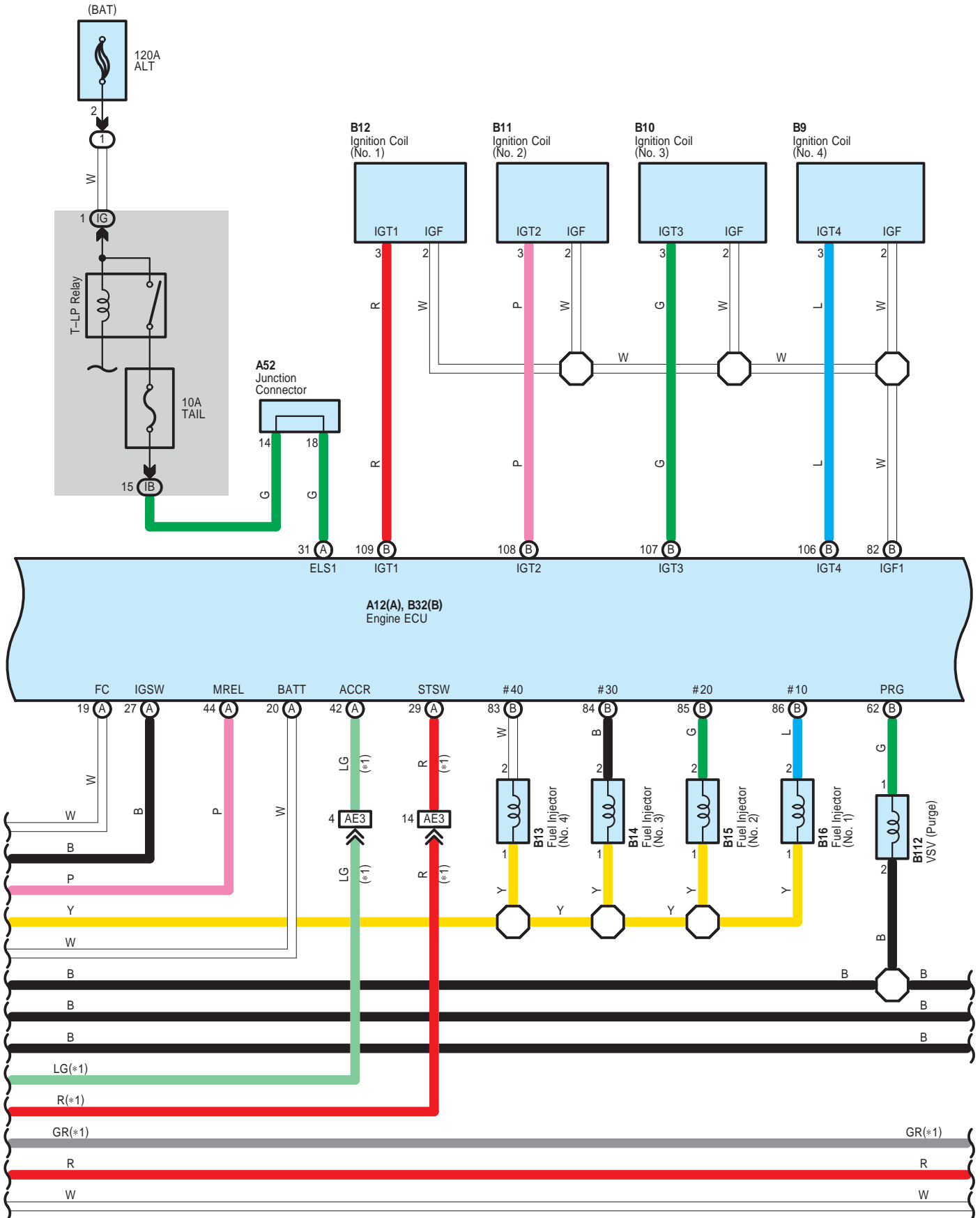

Engine Control <3ZR-FAE>

- \* 1 : w/ Entry & Start System
- \* 7 : Shielded

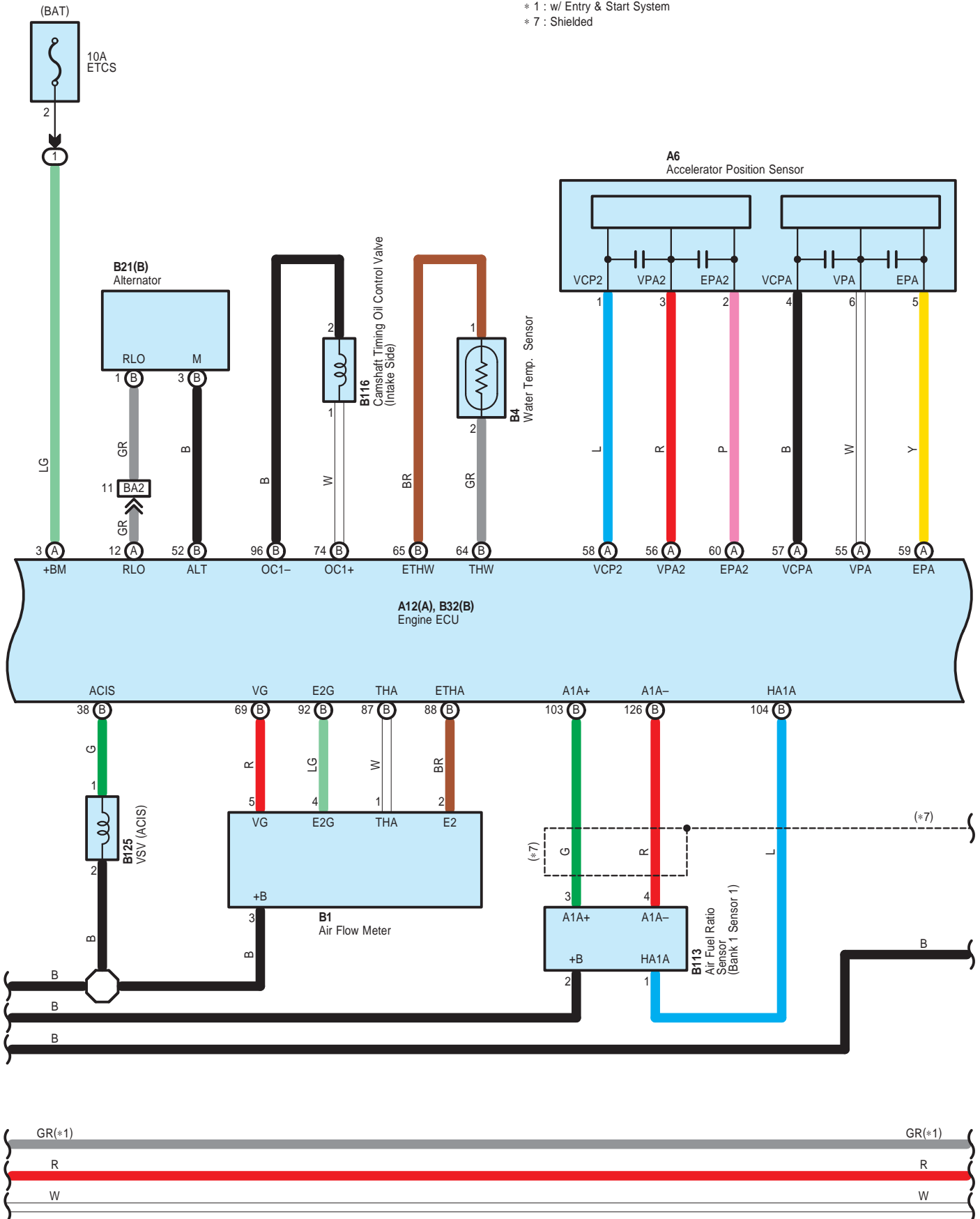

E50(A), (C)  
Transponder Key ECU  
E51(B)  
ID Code Box

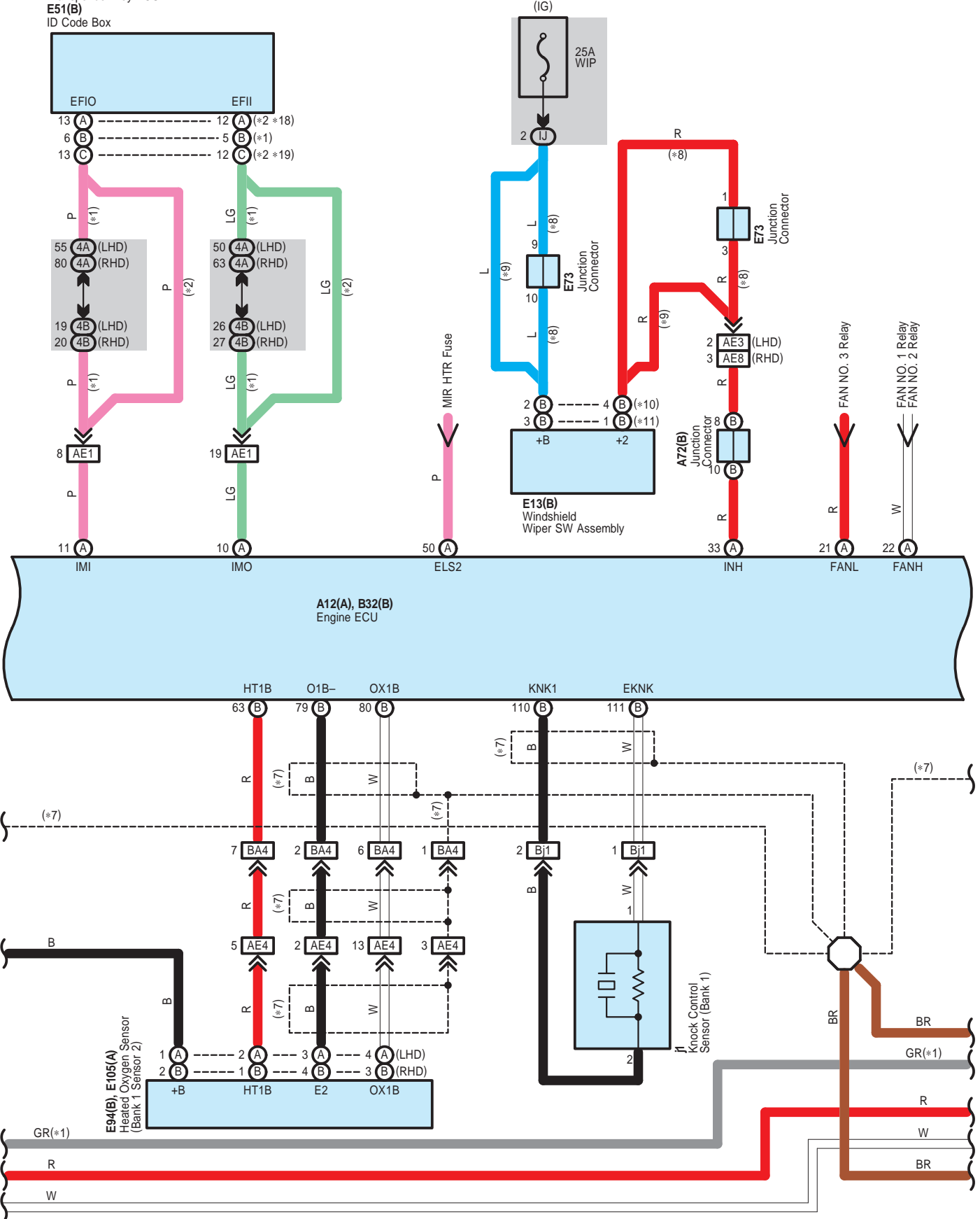

# Engine Control <3ZR-FAE>

- \* 1 : w/ Entry & Start System
- \* 2 : w/o Entry & Start System
- \* 7 : Shielded
- \* 8 : w/ Auto Wiper System
- \* 9 : w/o Auto Wiper System
- \* 10 : RH Wiper Lever Type
- \* 11 : LH Wiper Lever Type
- \* 18 : Before Aug. 2010 Production
- \* 19 : From Aug. 2010 Production

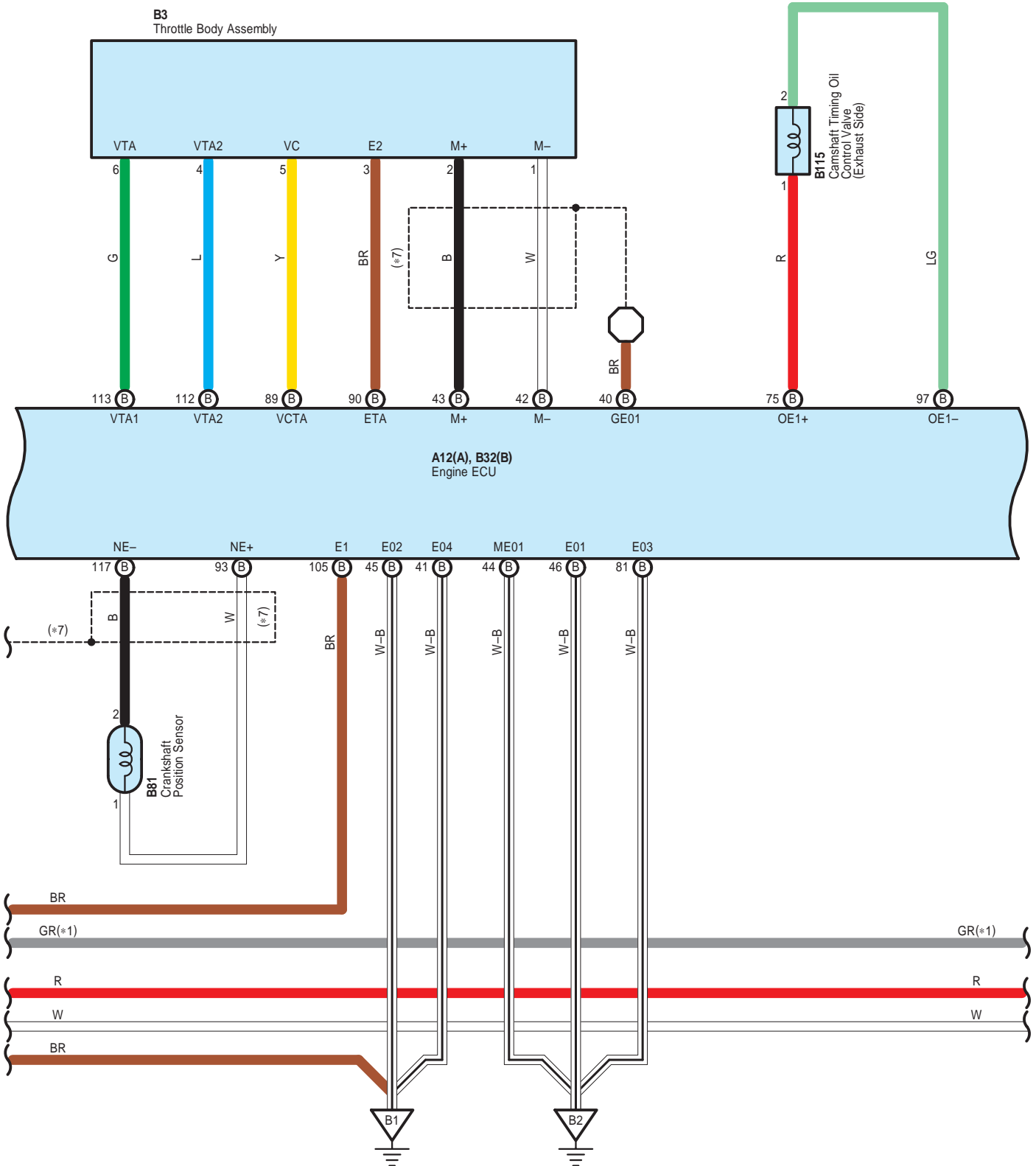



- \* 1 : w/ Entry & Start System
- \* 7 : Shielded

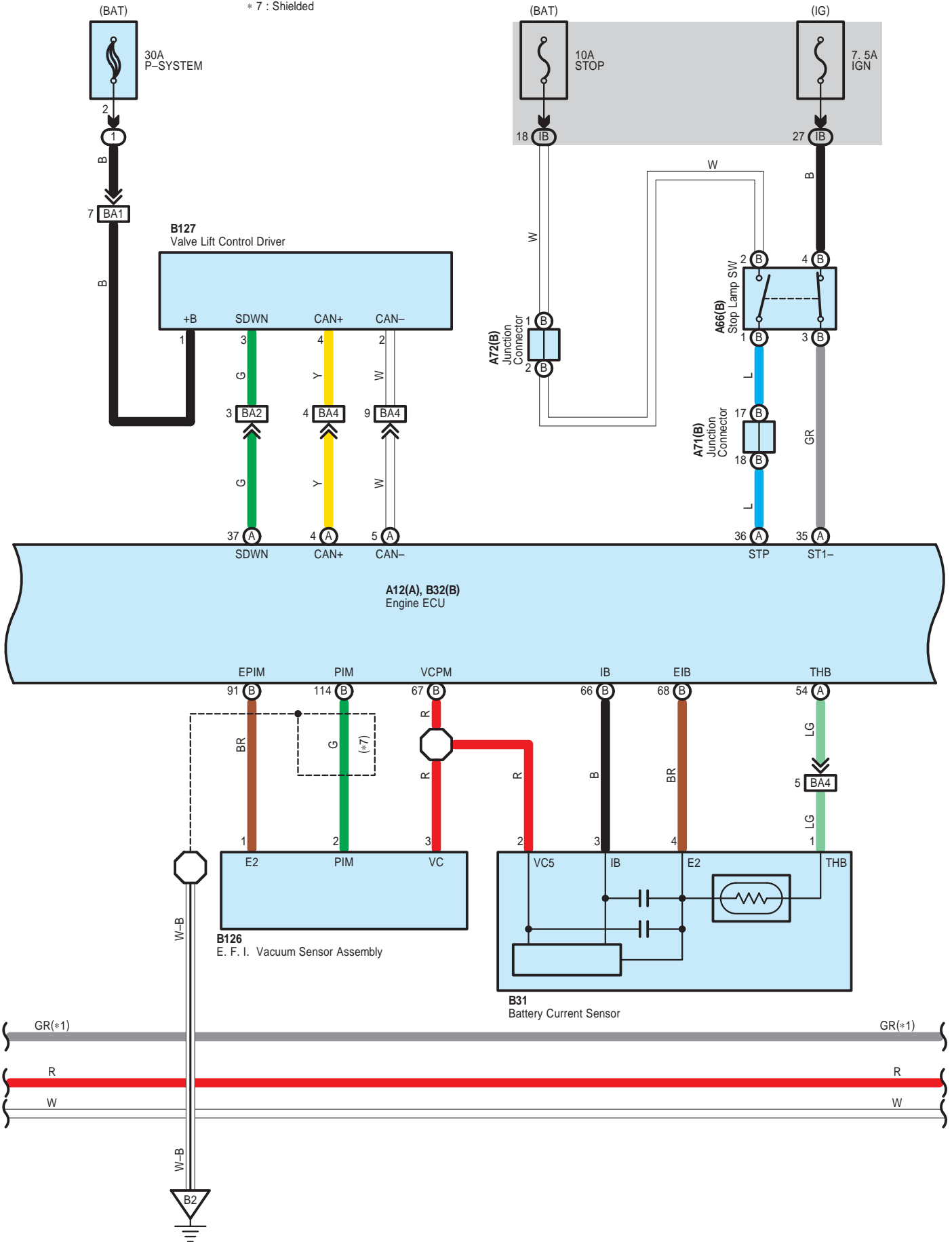

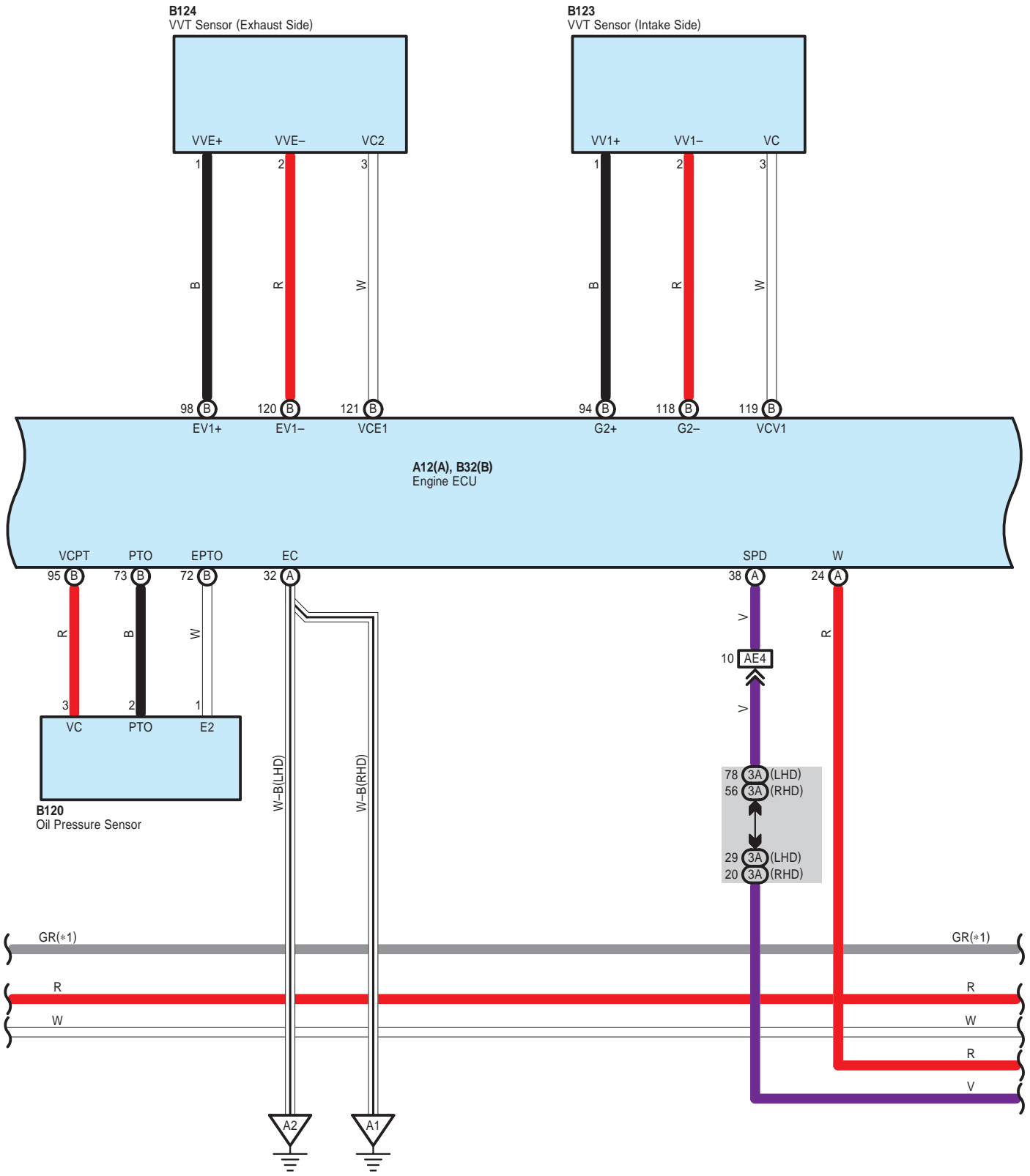

Engine Control <3ZR-FAE>

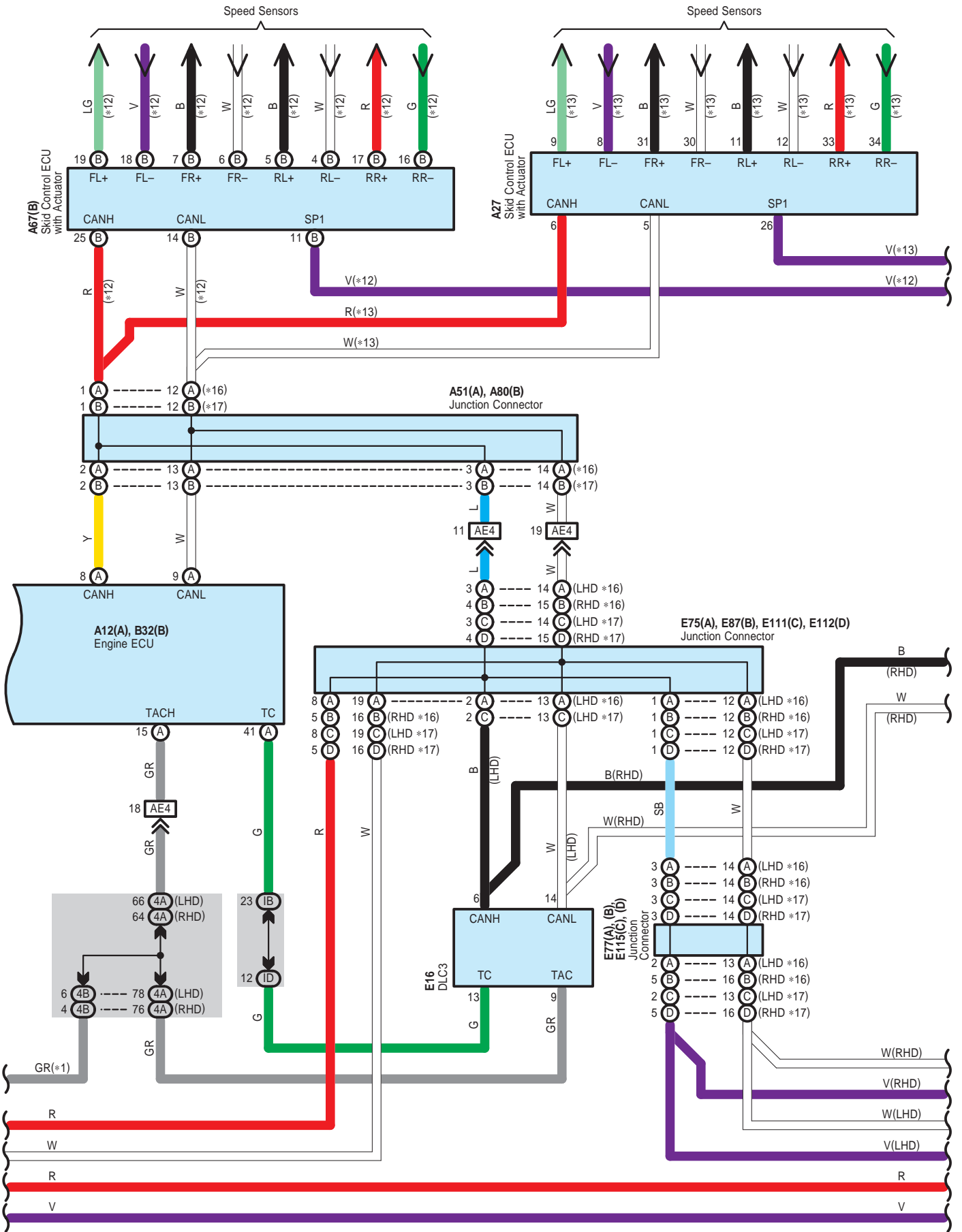

- \* 1 : w/ Entry & Start System
- \*12 : w/ VSC
- \*13 : w/o VSC
- \*16 : Before Feb. 2010 Production
- \*17 : From Feb. 2010 Production

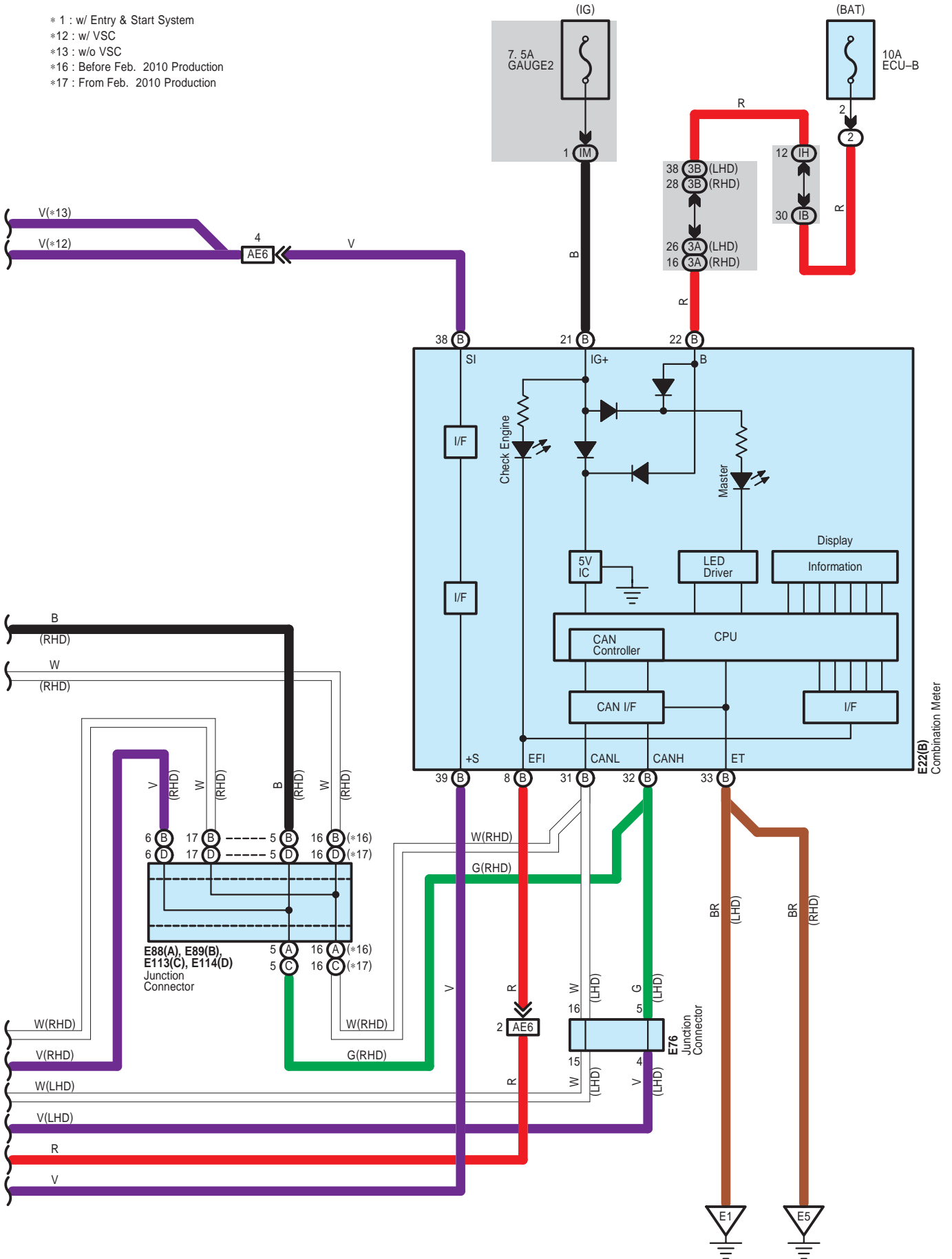

Engine Control <3ZR-FAE>

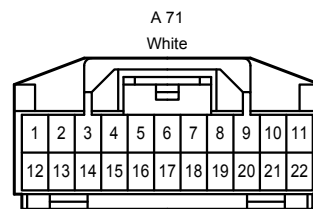
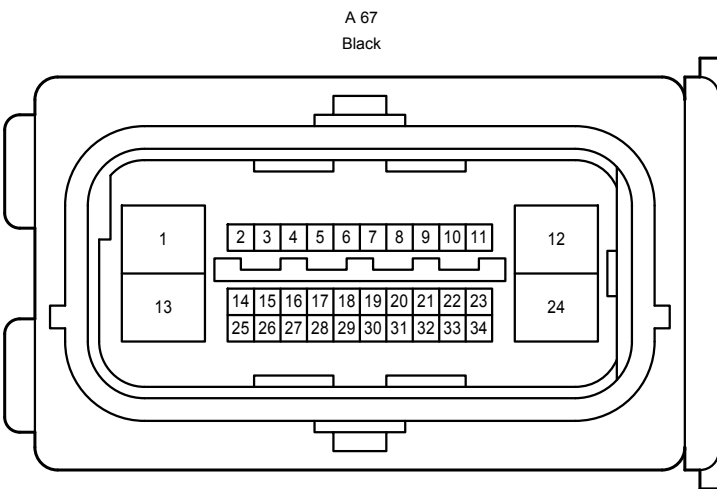
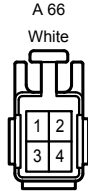
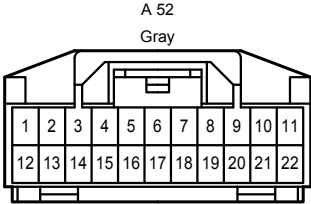
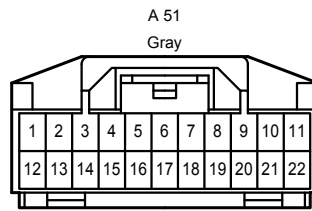
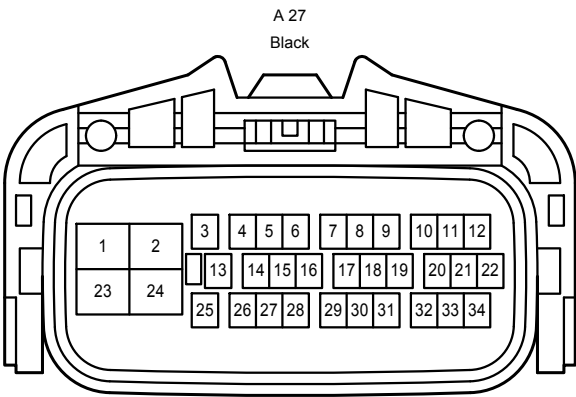
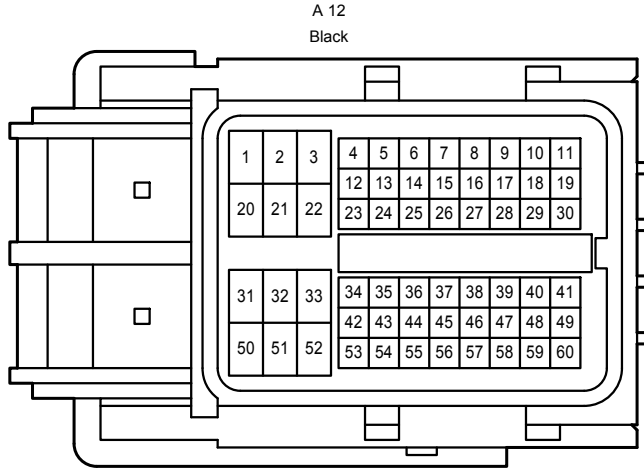
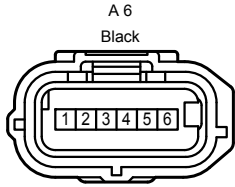
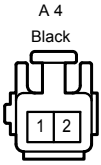



Engine Control <3ZR-FAE>

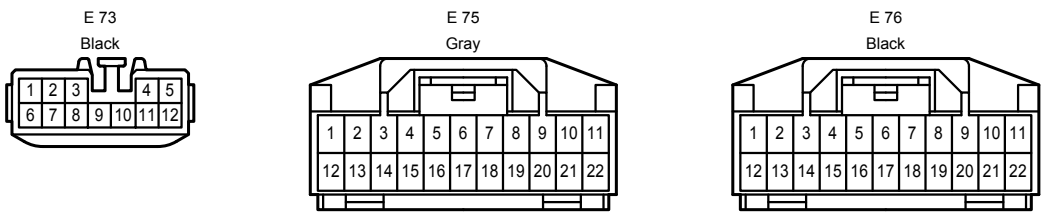
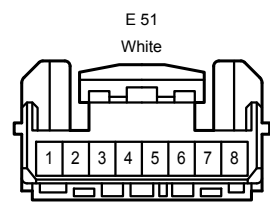
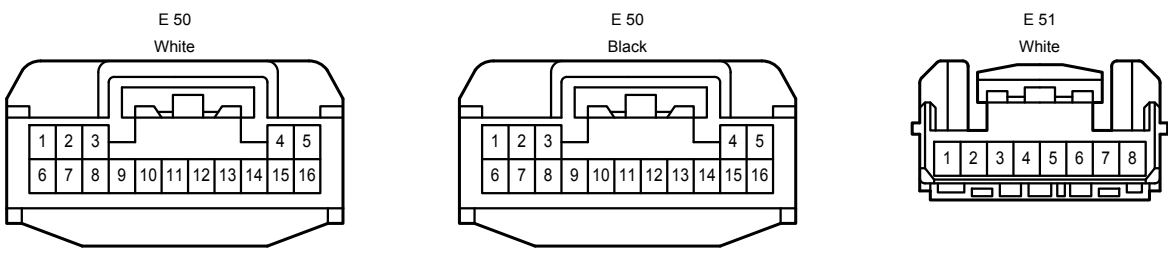
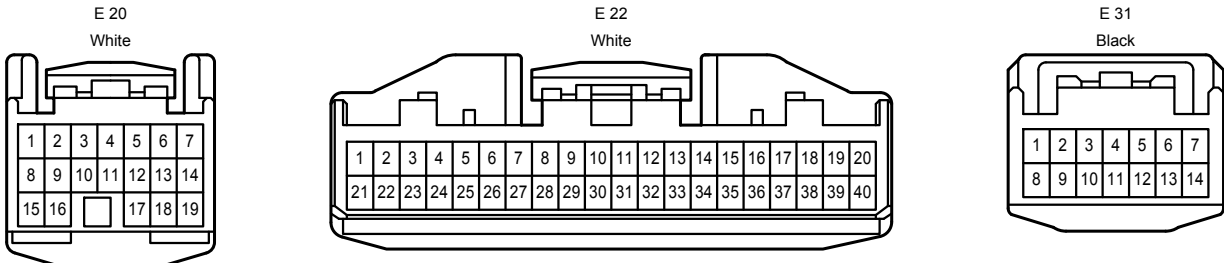
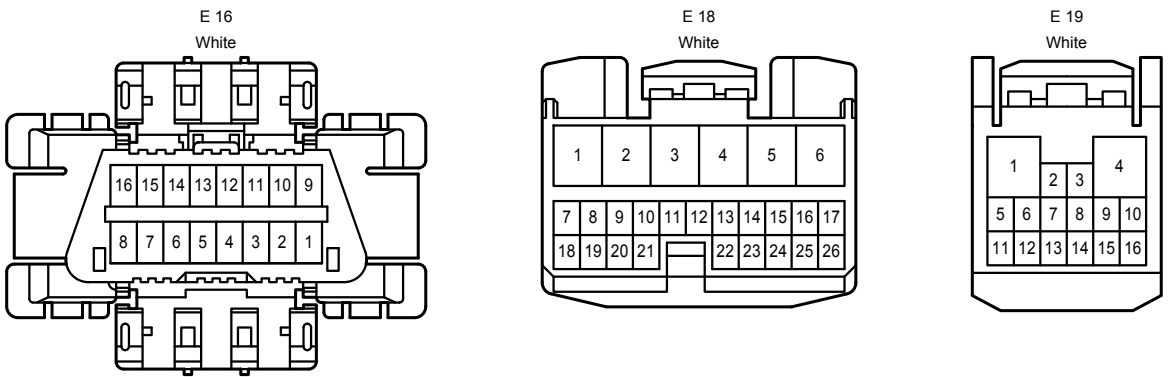
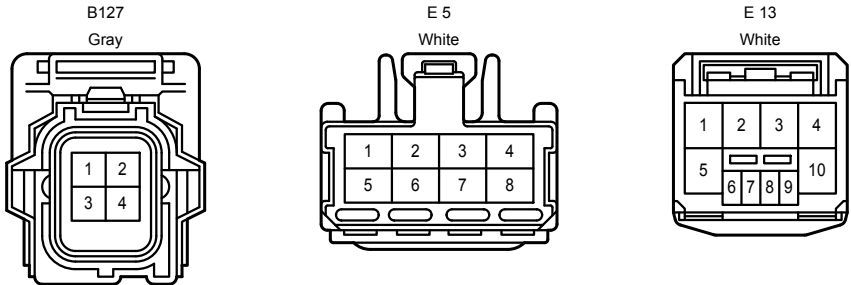
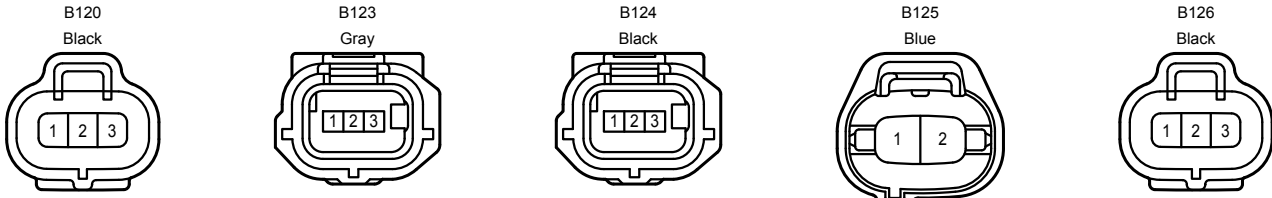

Engine Control <3ZR-FAE>

E 77  
Gray

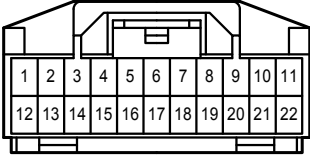

E 87  
Gray

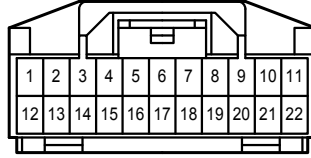

E 88  
Blue

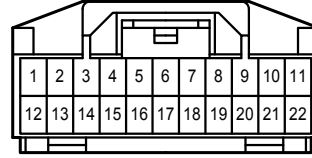

E 89  
Blue

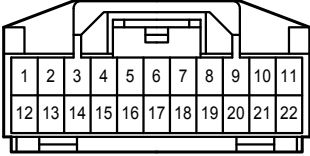

E 94  
Gray



E105  
Gray

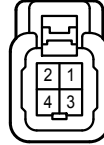

E111  
Gray

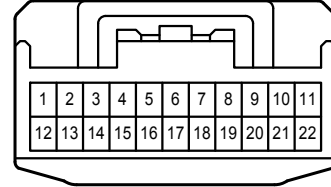

E112  
Gray

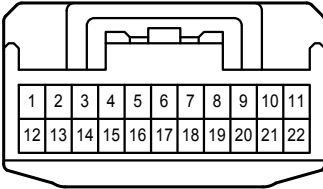

E113  
Black

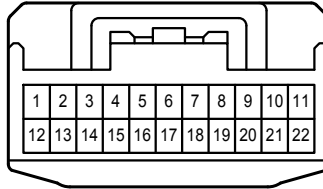

E114  
Black

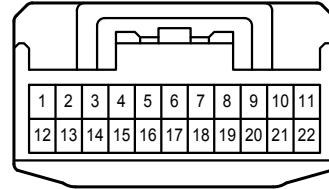

E115  
Gray

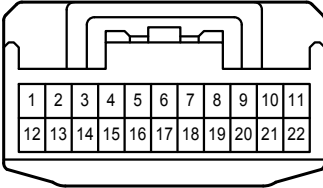

T 1  
White



j 1  
Black

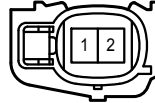

1A  
White

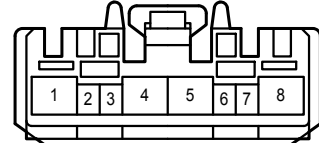

1B  
White

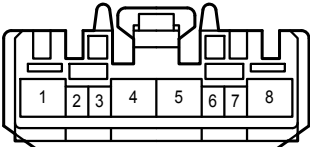

3A  
White

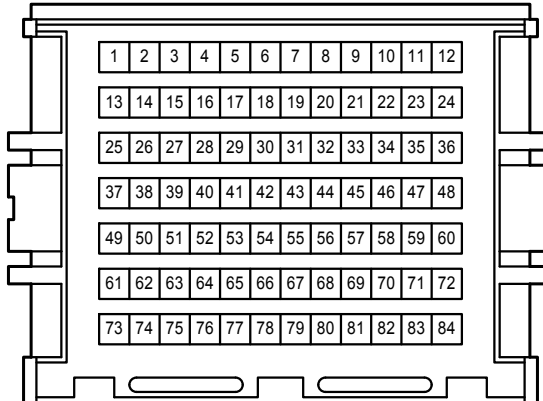



3B  
White

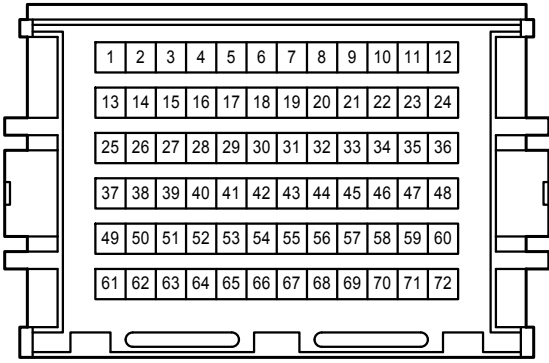

4A  
White

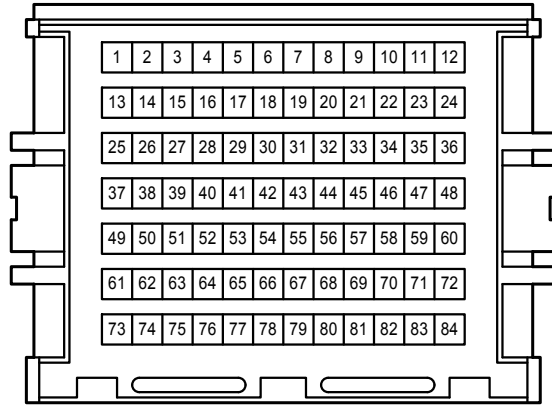

4B  
White

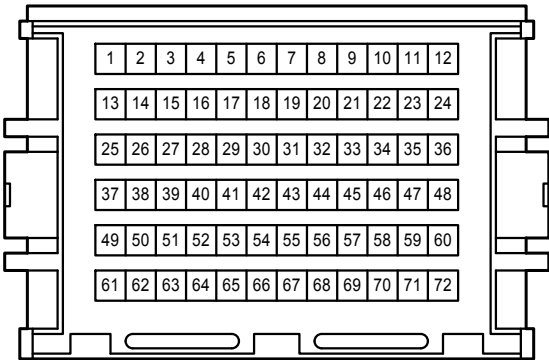

IA  
White

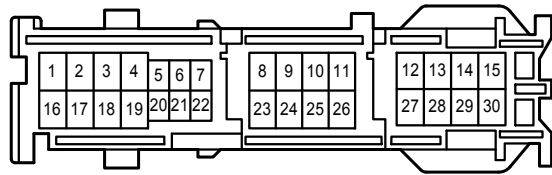

IB  
White

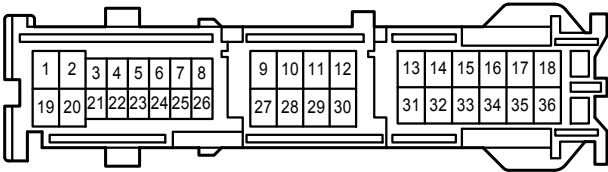

IC  
White

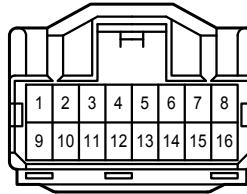

ID  
White

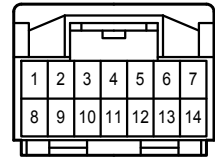

IE  
White

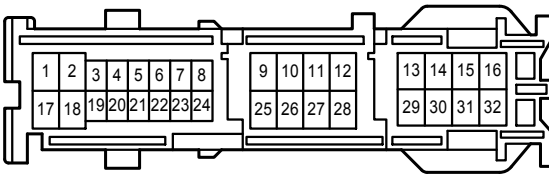

IF  
White

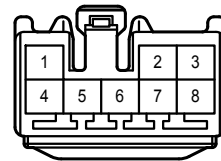

IG  
White

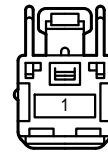

IH  
White

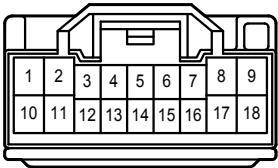

IJ  
White

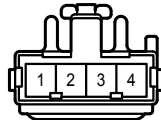

IM  
White

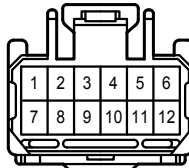

AE1  
White

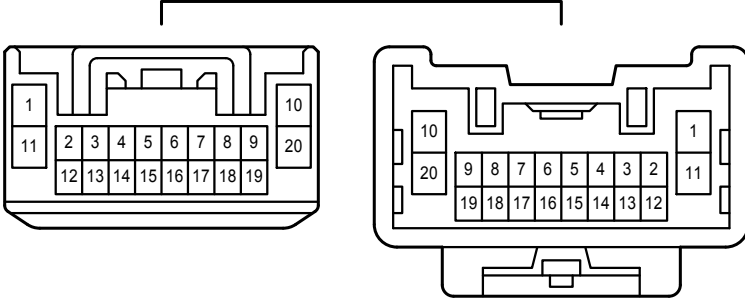

AE2  
White

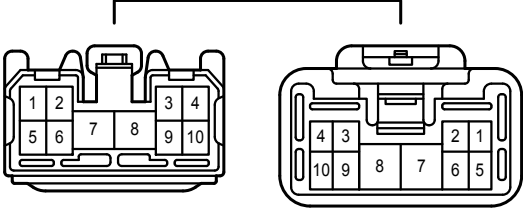

AE3  
Black

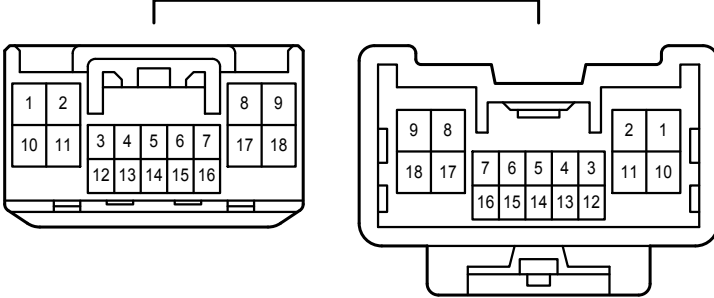

AE4  
Gray

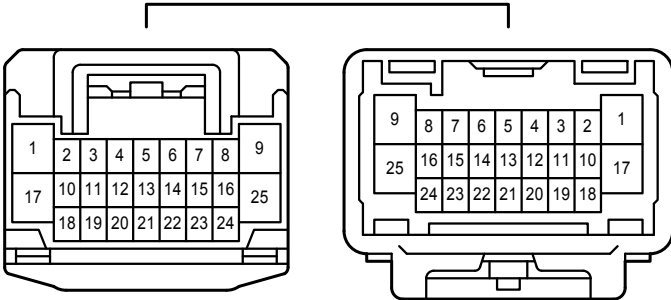

AE6  
White

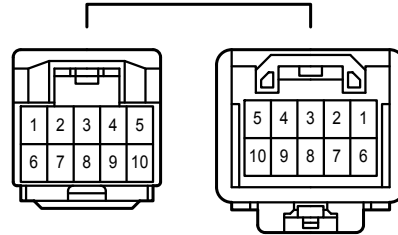

AE8  
White

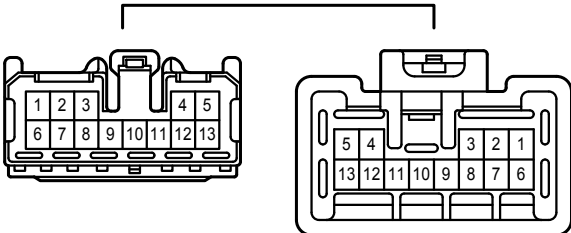

BA1  
White

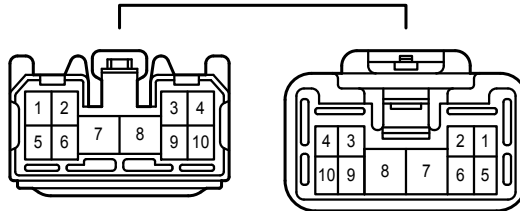

BA2  
Gray

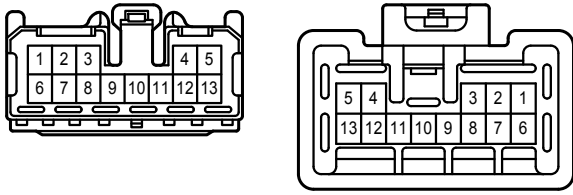

BA4  
White

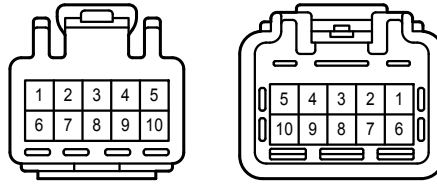

Bj1  
Gray

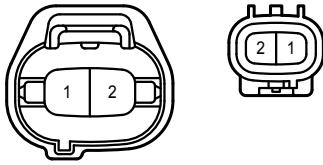

TK1  
White

