

Ground Point <LHD>

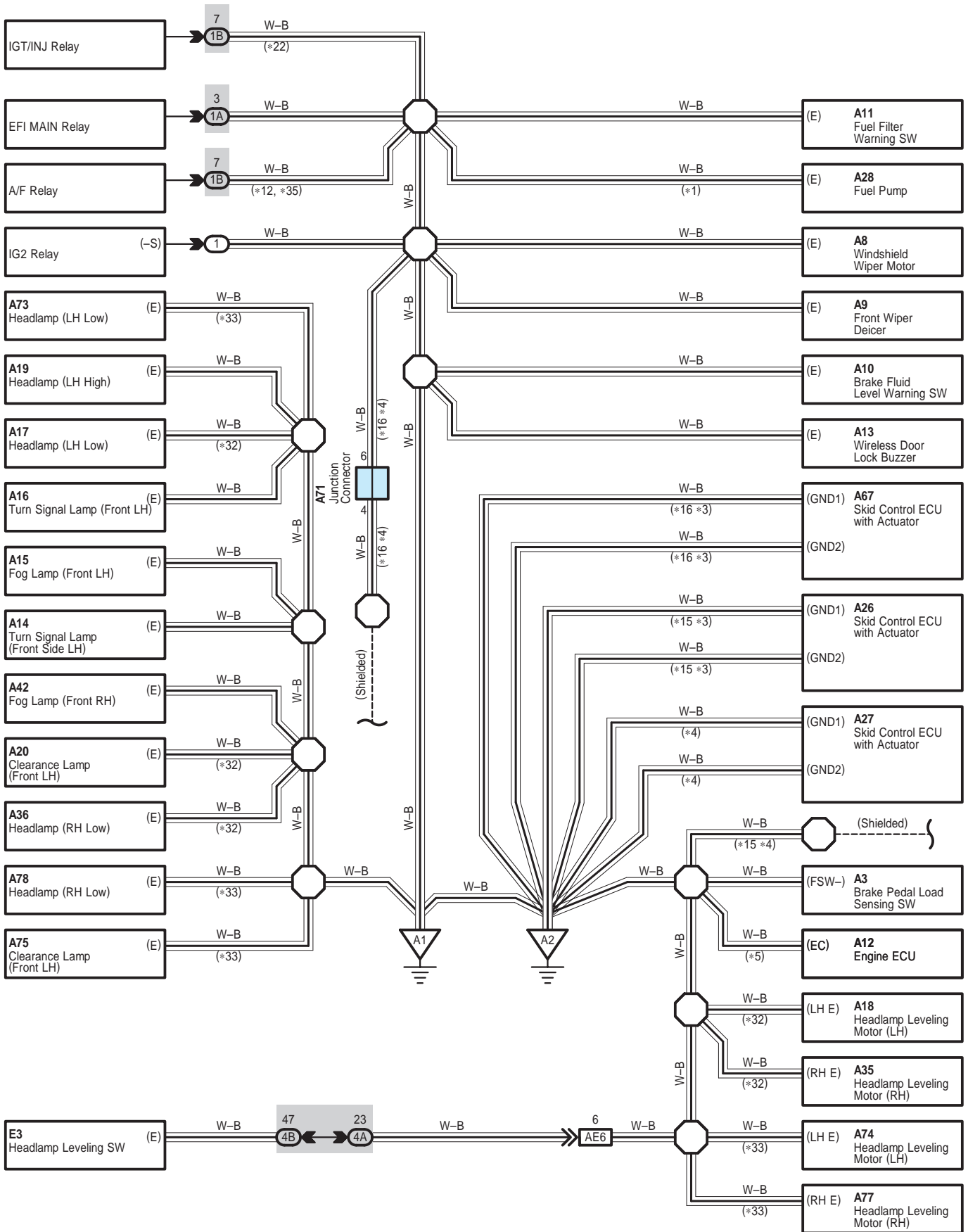

Ground Point <LHD>

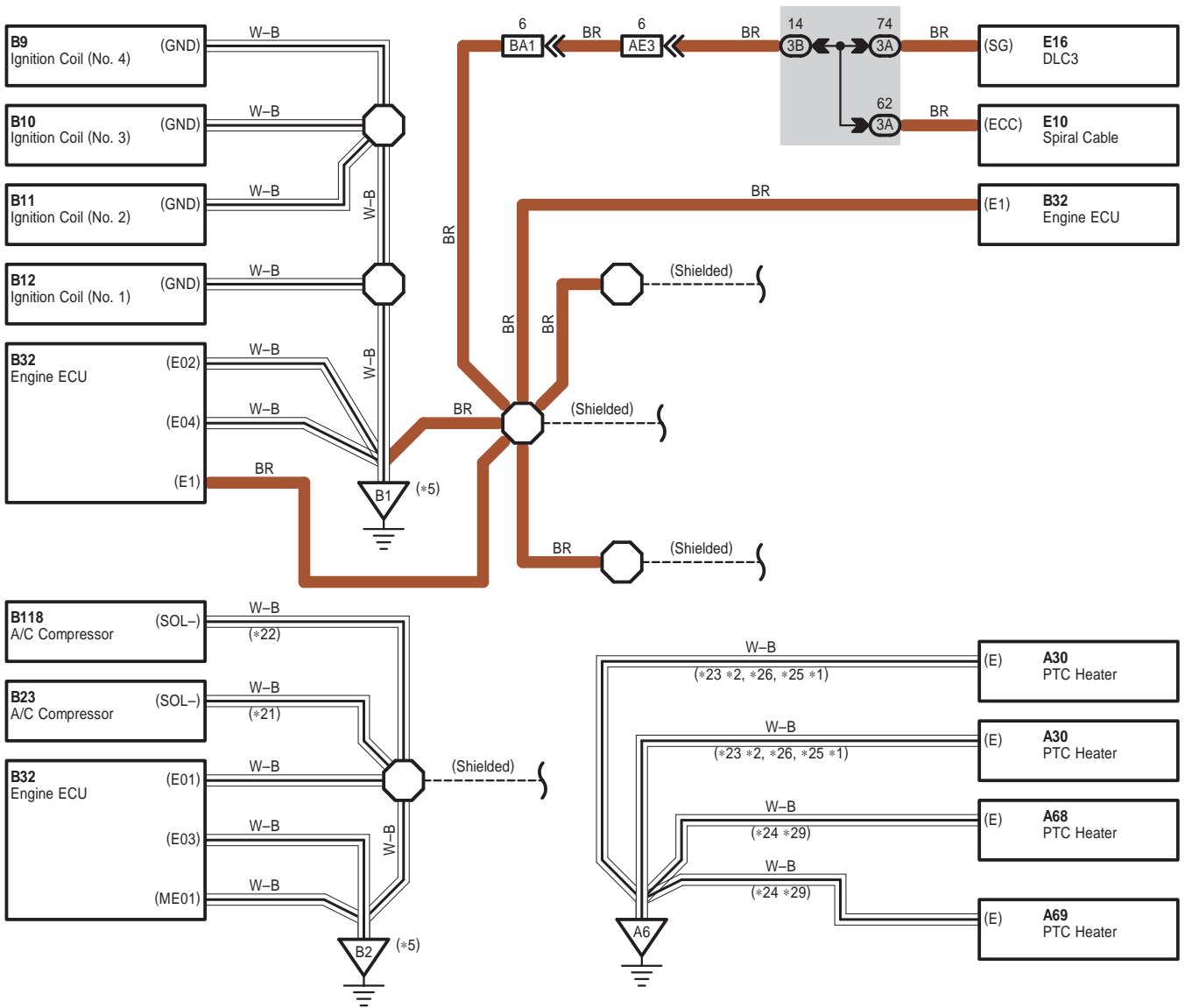

- * 1 : Diesel Cold Area Spec. Except A/T
- * 2 : Diesel Except Cold Area Spec.
- * 3 : w/ VSC
- * 4 : w/o VSC
- * 5 : Gasoline
- *12 : 2AD-FHV, 2AD-FTV w/ DPF
- *15 : Before Aug. 2008 Production Except Europe, Before Dec. 2008 Production Europe
- *16 : From Aug. 2008 Production Except Europe, From Dec. 2008 Production Europe
- *21 : 1AZ-FE, 2AZ-FE
- *22 : 3ZR-FAE
- *23 : Before Dec. 2008 Production Europe
- *24 : From Dec. 2008 Production Europe
- *25 : From Dec. 2008 Production Europe
- *26 : 3ZR-FAE Cold Area Spec.
- *29 : Diesel Except Cold Area Spec. Except A/T
- *32 : w/o Hood Molding
- *33 : w/ Hood Molding
- *35 : Except 3ZR-FAE

Ground Point <LHD>

* 7 : w/ Entry & Start System

* 8 : Automatic A/C

* 9 : Manual A/C

*15 : Before Aug. 2008 Production Except Europe,
Before Dec. 2008 Production Europe

*16 : From Aug. 2008 Production Except Europe,
From Dec. 2008 Production Europe

*17 : Before Dec. 2008 Production Europe

*18 : From Dec. 2008 Production Europe

*19 : w/ Rear View Monitor Mirror

*20 : w/o Rear View Monitor Mirror

*30 : Before Aug. 2009 Production

*31 : From Aug. 2009 Production

*36 : Before Feb. 2010 Production

*37 : From Feb. 2010 Production

*41 : Before Aug. 2010 Production

*42 : From Aug. 2010 Production

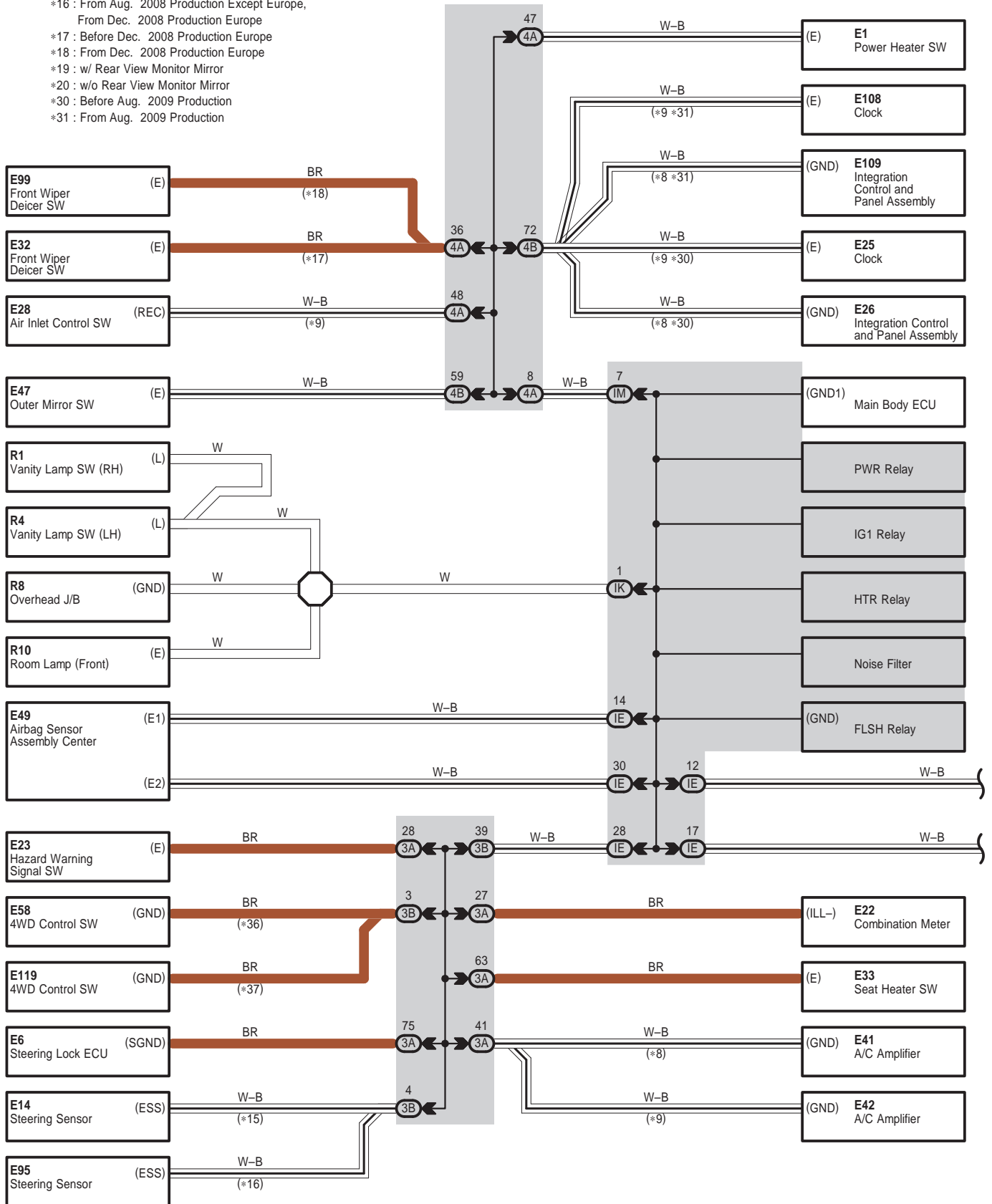

Ground Point <LHD>

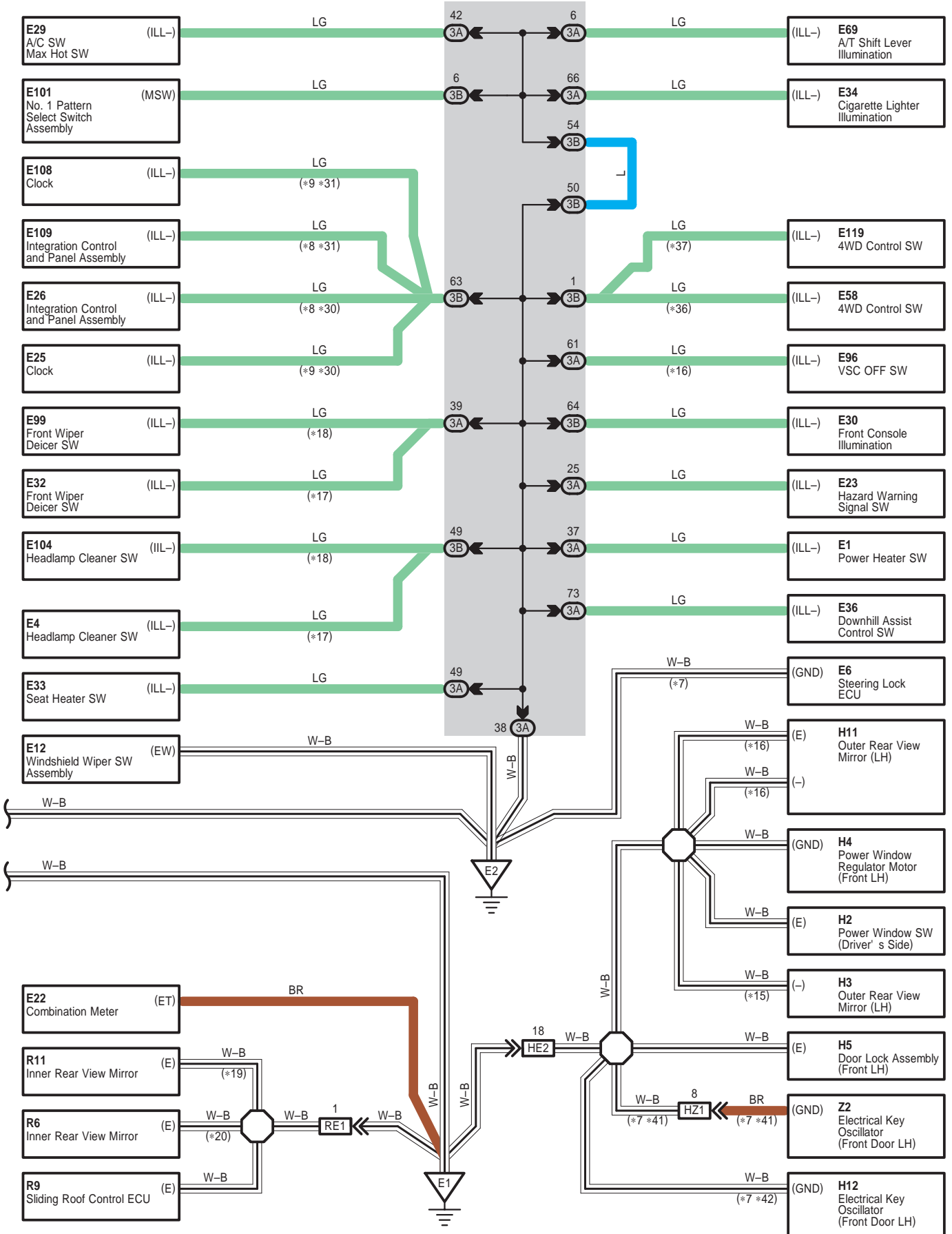

Ground Point <LHD>

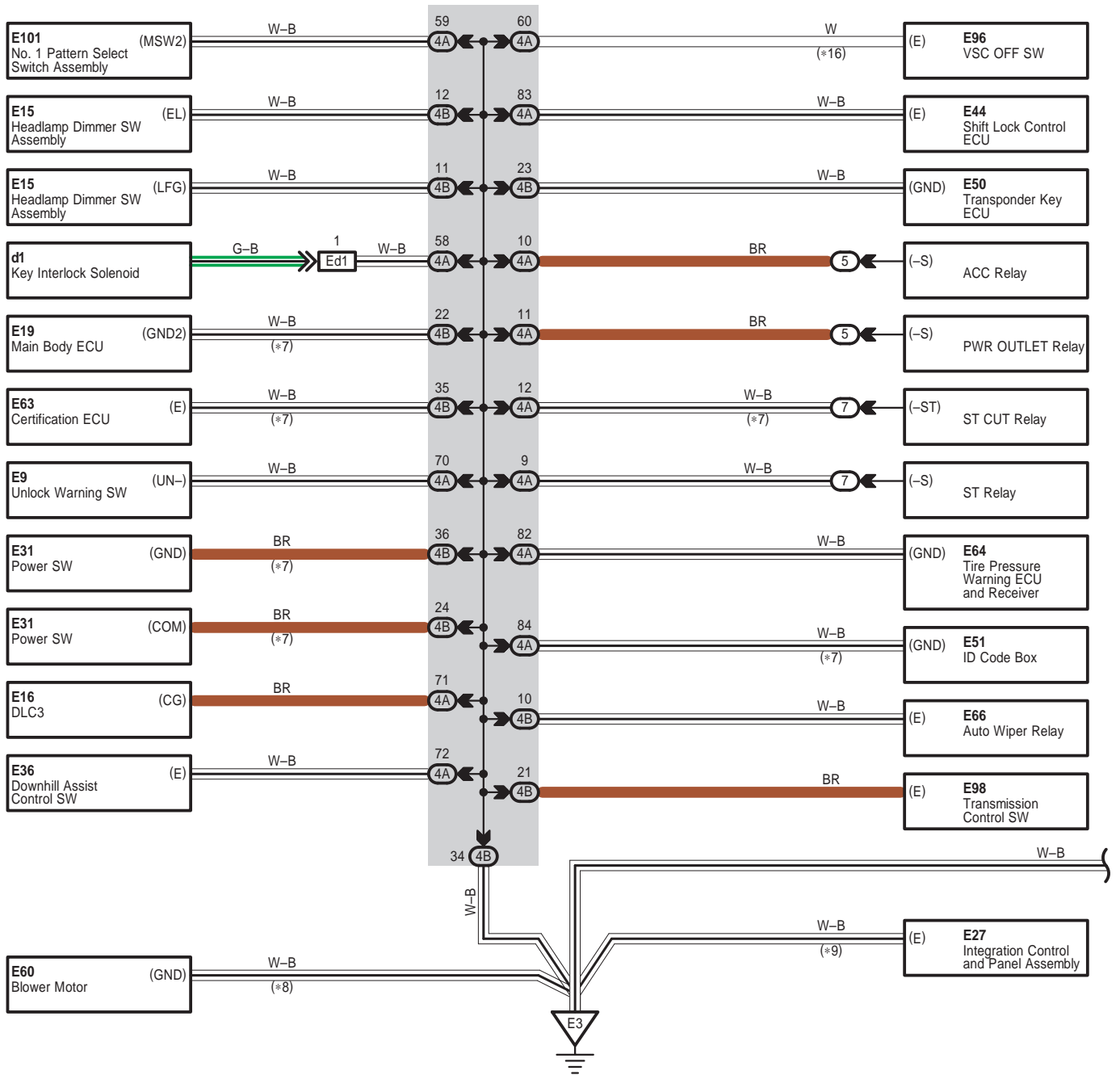

- * 6 : Diesel
- * 7 : w/ Entry & Start System
- * 8 : Automatic A/C
- * 9 : Manual A/C
- *15 : Before Aug. 2008 Production Except Europe,
Before Dec. 2008 Production Europe
- *16 : From Aug. 2008 Production Except Europe,
From Dec. 2008 Production Europe
- *17 : Before Dec. 2008 Production Europe
- *18 : From Dec. 2008 Production Europe
- *36 : Before Feb. 2010 Production
- *39 : From Feb. 2010 Production until Aug. 2010 Production
- *40 : *36, *42
- *41 : Before Aug. 2010 Production
- *42 : From Aug. 2010 Production

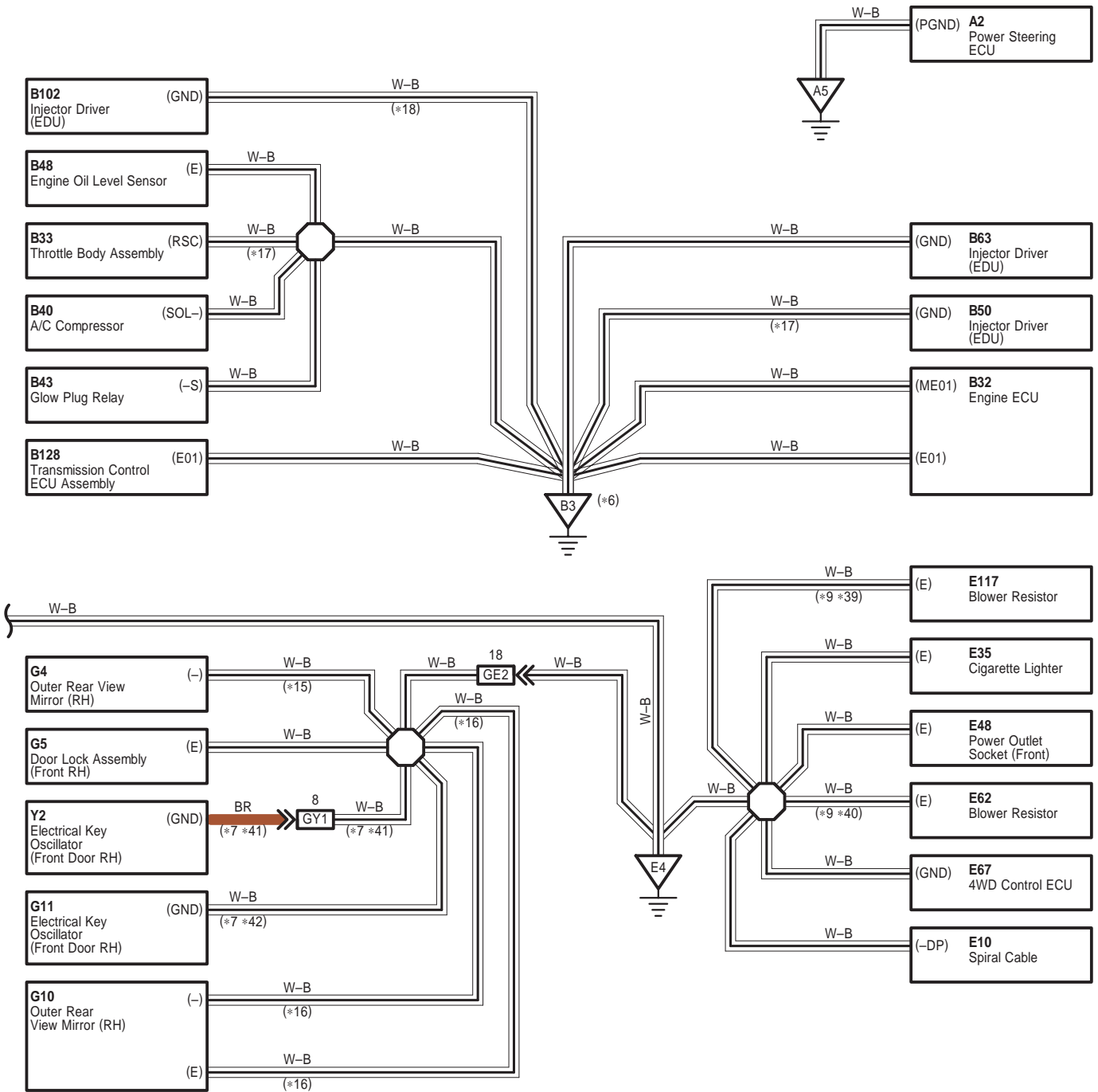

Ground Point <LHD>

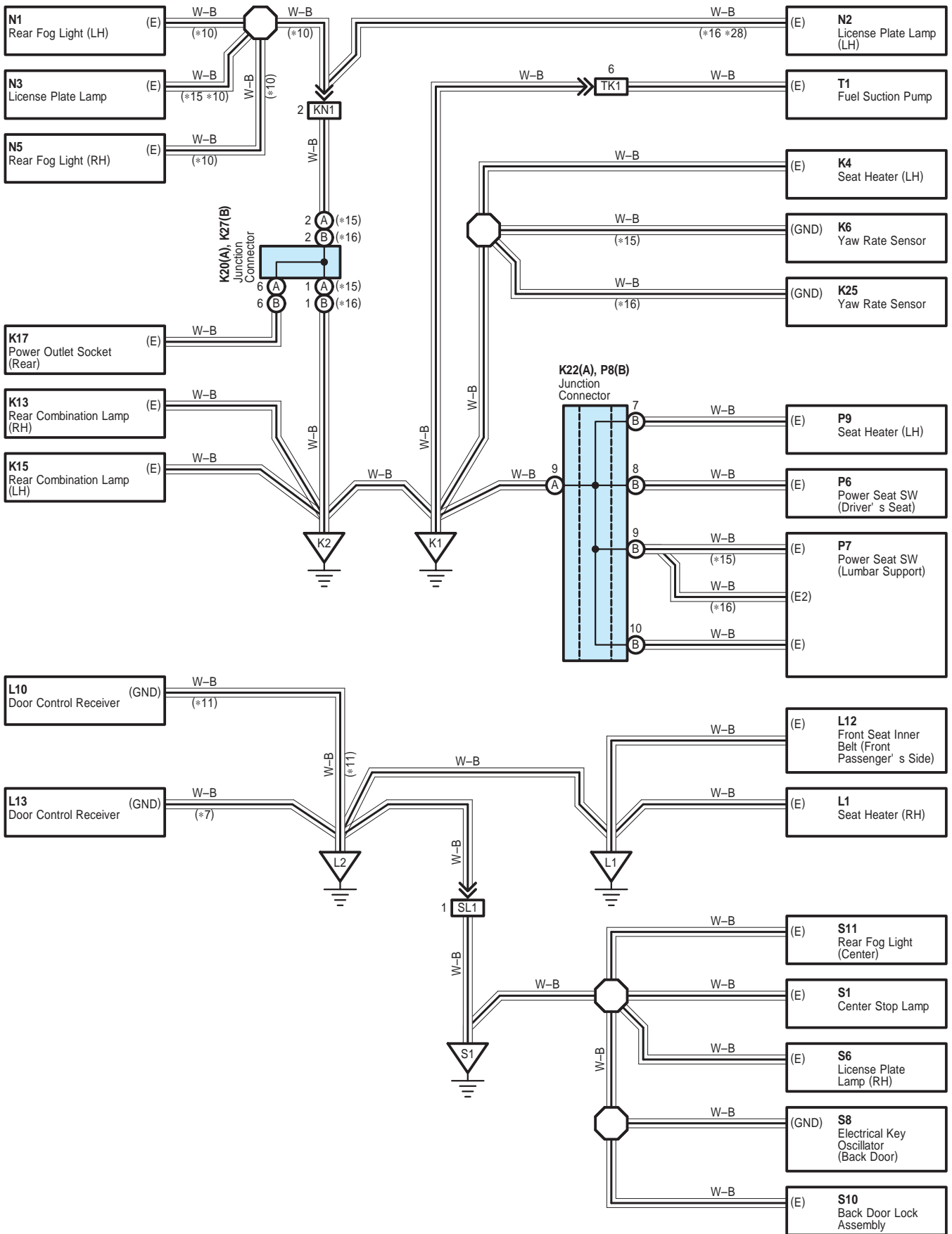

Ground Point <LHD>

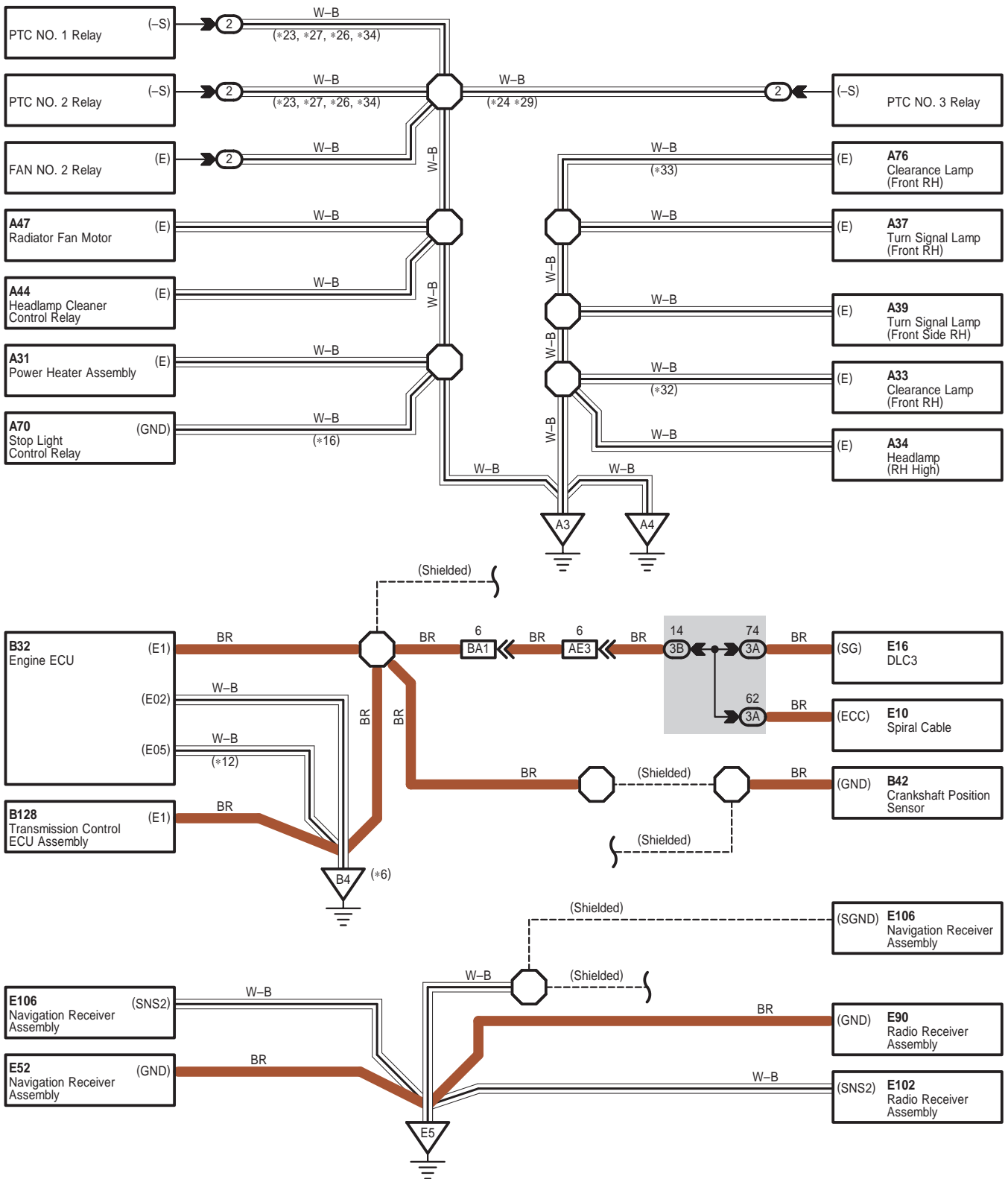

- * 6 : Diesel
- * 7 : w/ Entry & Start System
- * 10 : Short Body
- * 11 : w/o Entry & Start System
- * 12 : 2AD-FHV, 2AD-FTV w/ DPF
- * 15 : Before Aug. 2008 Production Except Europe, Before Dec. 2008 Production Europe
- * 16 : From Aug. 2008 Production Except Europe, From Dec. 2008 Production Europe
- * 23 : Before Dec. 2008 Production Europe
- * 24 : From Dec. 2008 Production Europe
- * 26 : 3ZR-FAE Cold Area Spec.
- * 27 : From Dec. 2008 Production Diesel
- * 28 : Long Body
- * 29 : Diesel Except Cold Area Spec. Except A/T
- * 32 : w/o Hood Molding
- * 33 : w/ Hood Molding
- * 34 : Diesel Except Cold Area Spec.

A 71
White

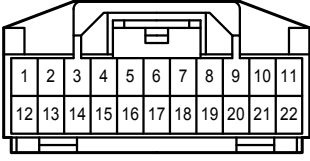

K 20
Black

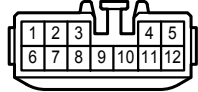

K 22
White

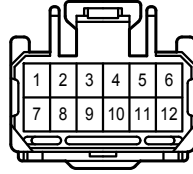

K 27
Gray

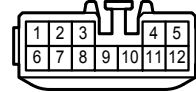

P 8
Gray

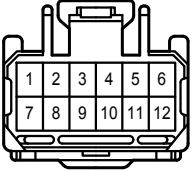

1A
White

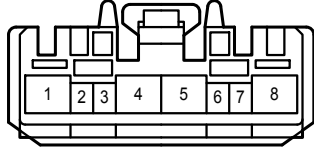

1B
White

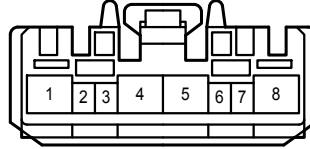

3A
White

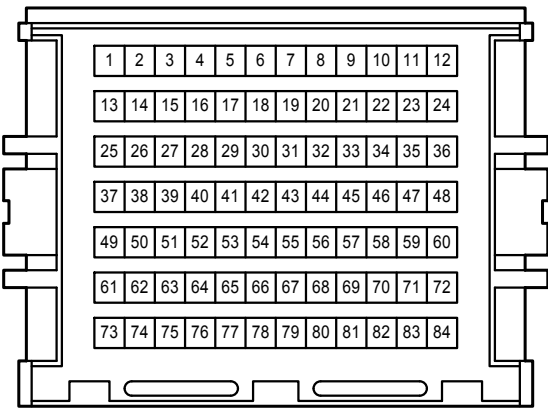

3B
White

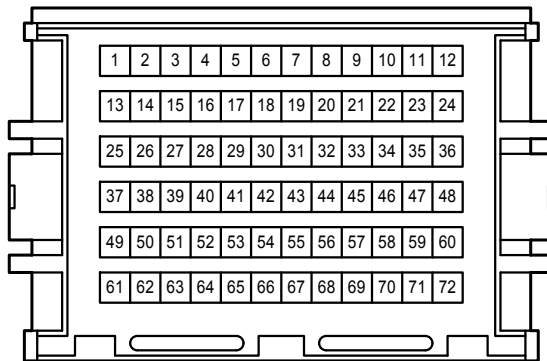

4A
White

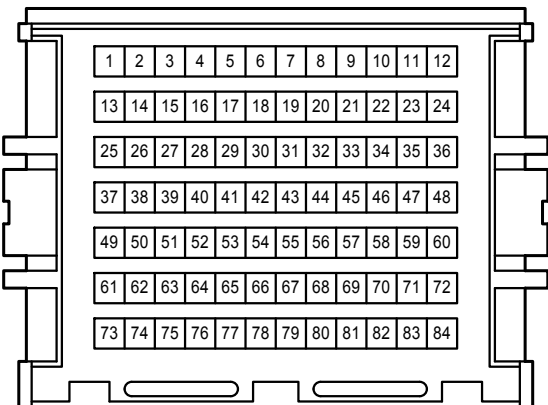

4B
White

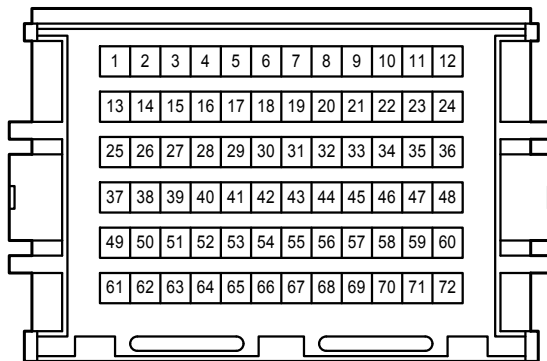

1E
White

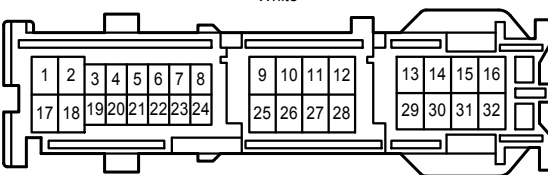

1K
White

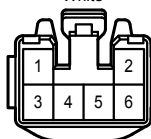

1M
White

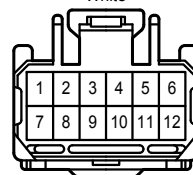

AE3
Black

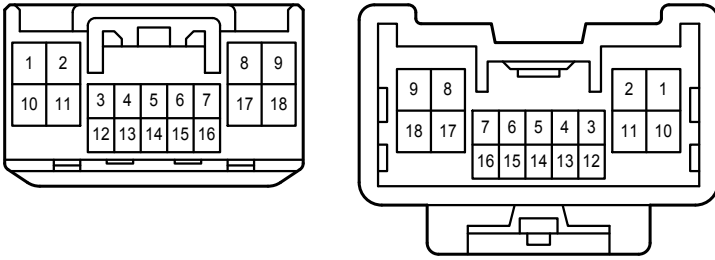

AE6
White

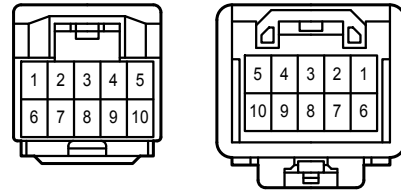

BA1
White

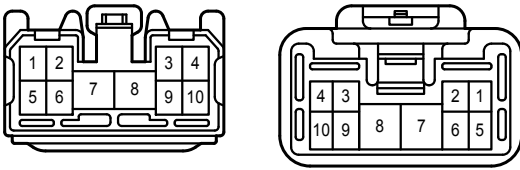

Ed1
Black

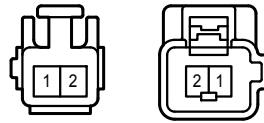

GE2
White

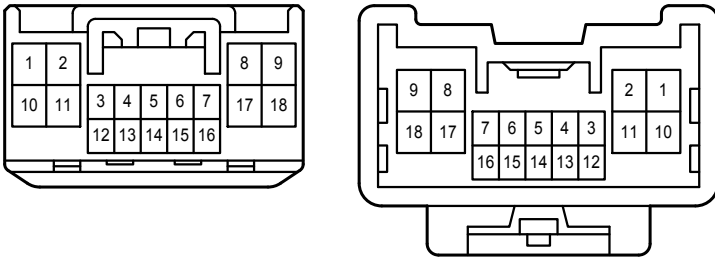

GY1
Gray

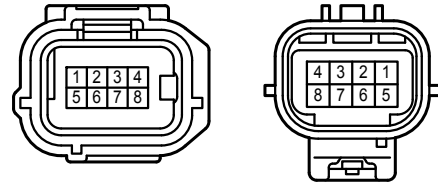

HE2
White

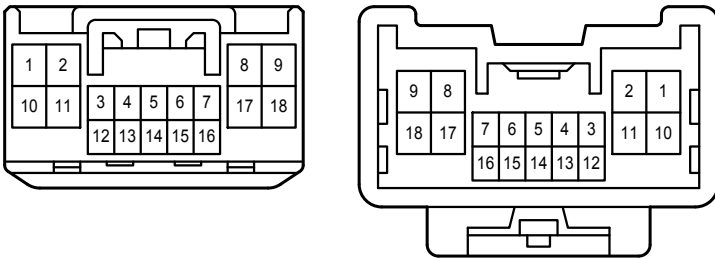

HZ1
Gray

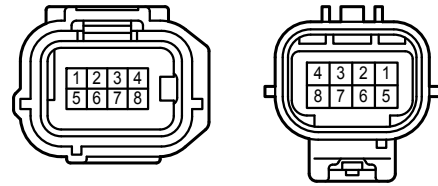

KN1
White

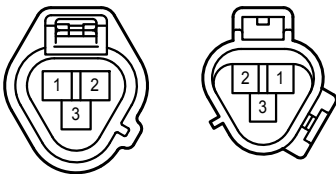

RE1
White

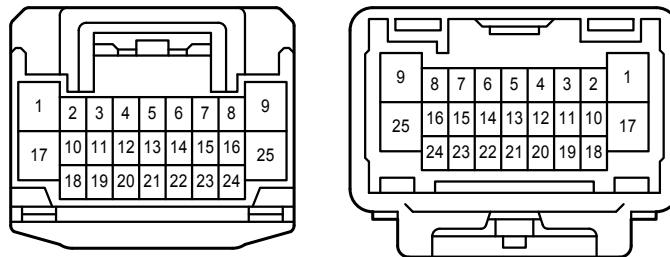

SL1
White

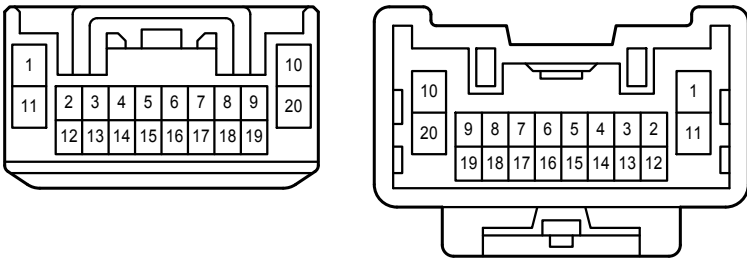

TK1
White

