

Ground Point <RHD>

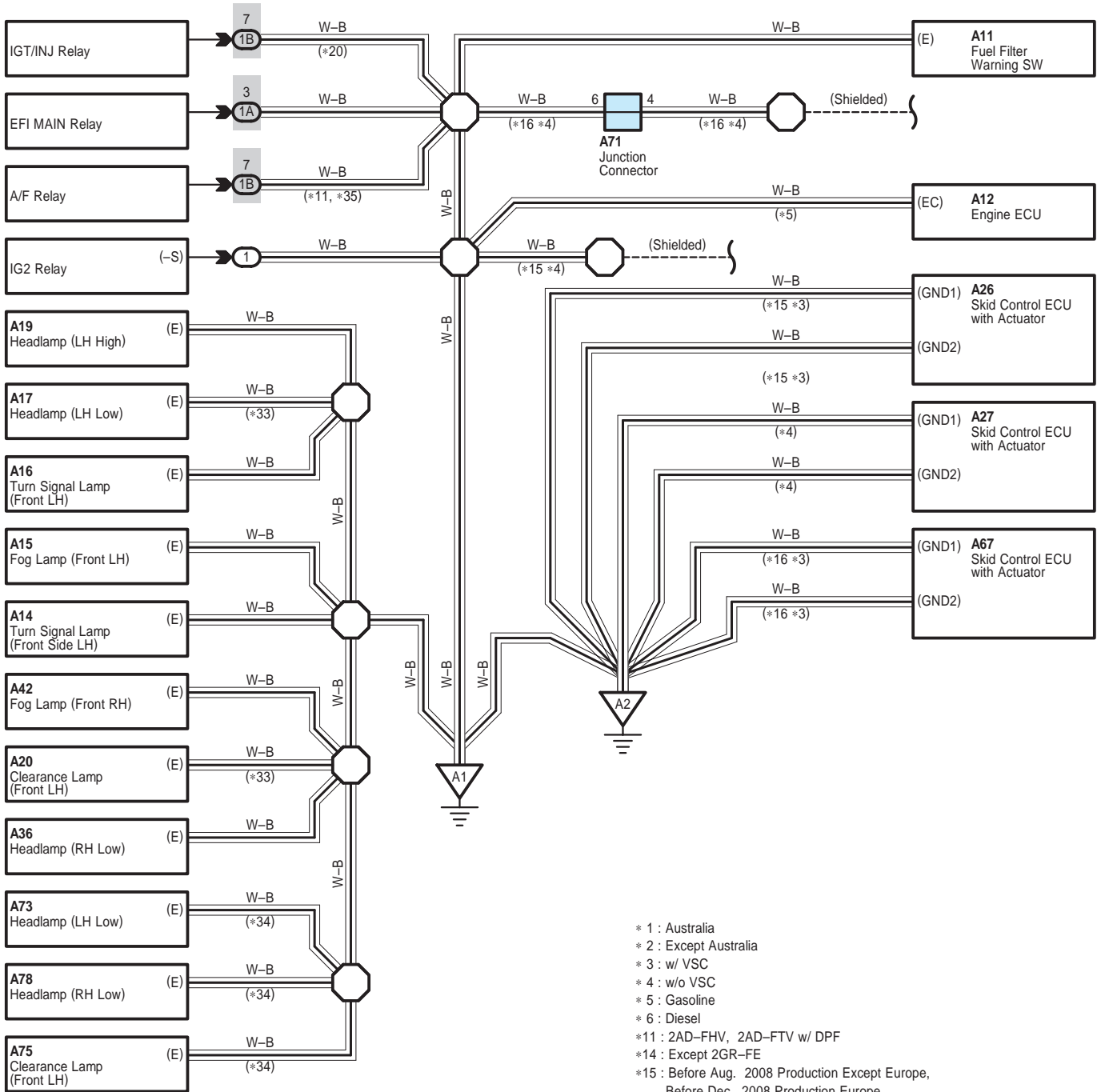

- * 1 : Australia
- * 2 : Except Australia
- * 3 : w/ VSC
- * 4 : w/o VSC
- * 5 : Gasoline
- * 6 : Diesel
- *11 : 2AD-FHV, 2AD-FTV w/ DPF
- *14 : Except 2GR-FE
- *15 : Before Aug. 2008 Production Except Europe, Before Dec. 2008 Production Europe
- *16 : From Aug. 2008 Production Except Europe, From Dec. 2008 Production Europe
- *19 : 1AZ-FE, 2AZ-FE
- *20 : 3ZR-FAE
- *21 : Before Dec. 2008 Production Europe
- *22 : From Dec. 2008 Production Europe
- *23 : Diesel Except Cold Area Spec.
- *25 : 3ZR-FAE Cold Area Spec.
- *26 : *22 Diesel Cold Area Spec. Except A/T
- *33 : w/o Hood Molding
- *34 : w/ Hood Molding
- *35 : Except 3ZR-FAE

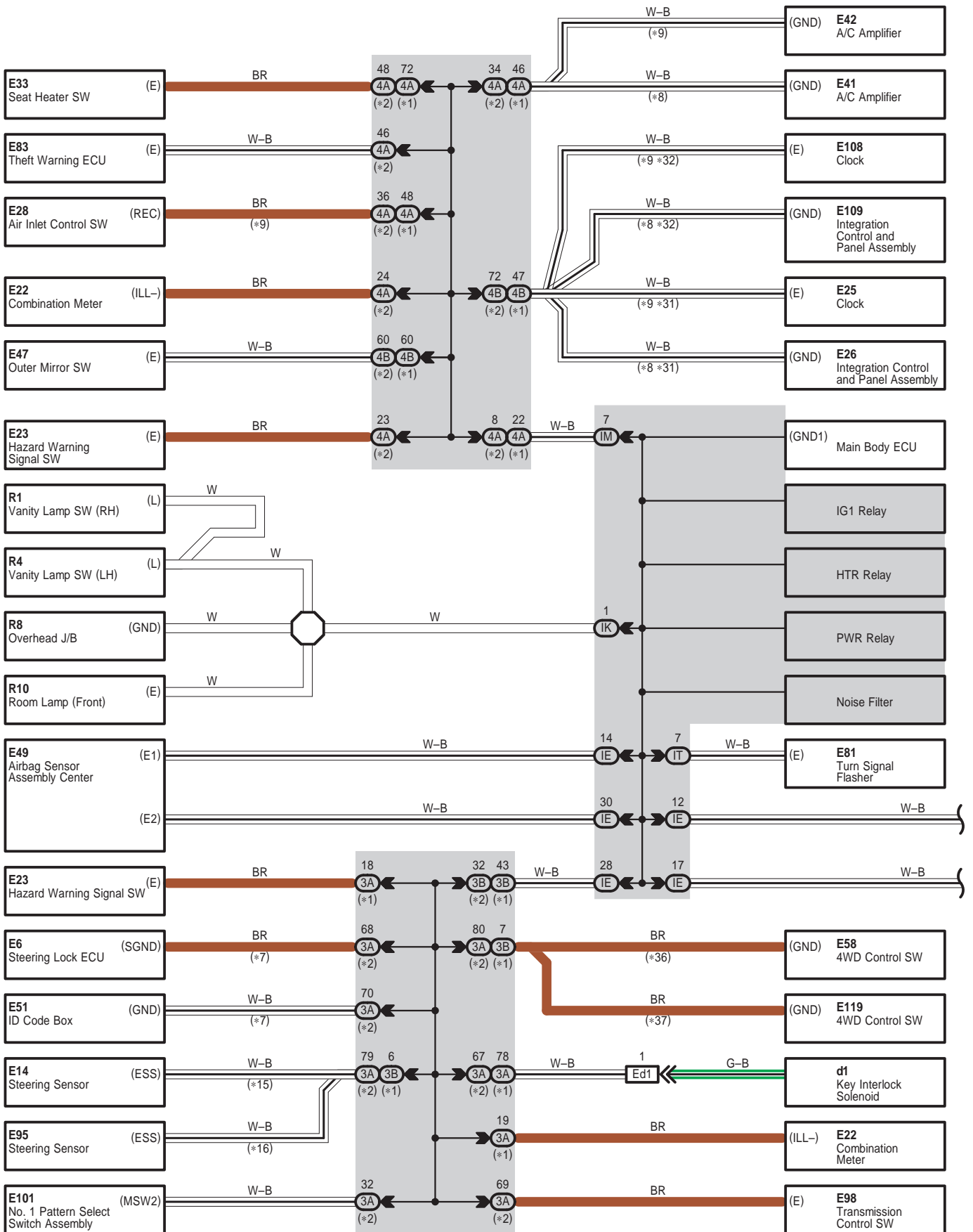

Ground Point <RHD>

- * 1 : Australia
- * 2 : Except Australia
- * 7 : w/ Entry & Start System
- * 8 : Automatic A/C
- * 9 : Manual A/C
- *15 : Before Aug. 2008 Production Except Europe,
Before Dec. 2008 Production Europe
- *16 : From Aug. 2008 Production Except Europe,
From Dec. 2008 Production Europe
- *17 : w/ Rear View Monitor Mirror
- *18 : w/o Rear View Monitor Mirror
- *31 : Before Aug. 2009 Production
- *32 : From Aug. 2009 Production
- *36 : Before Feb. 2010 Production
- *37 : From Feb. 2010 Production
- *38 : Before Aug. 2010 Production
- *39 : From Aug. 2010 Production

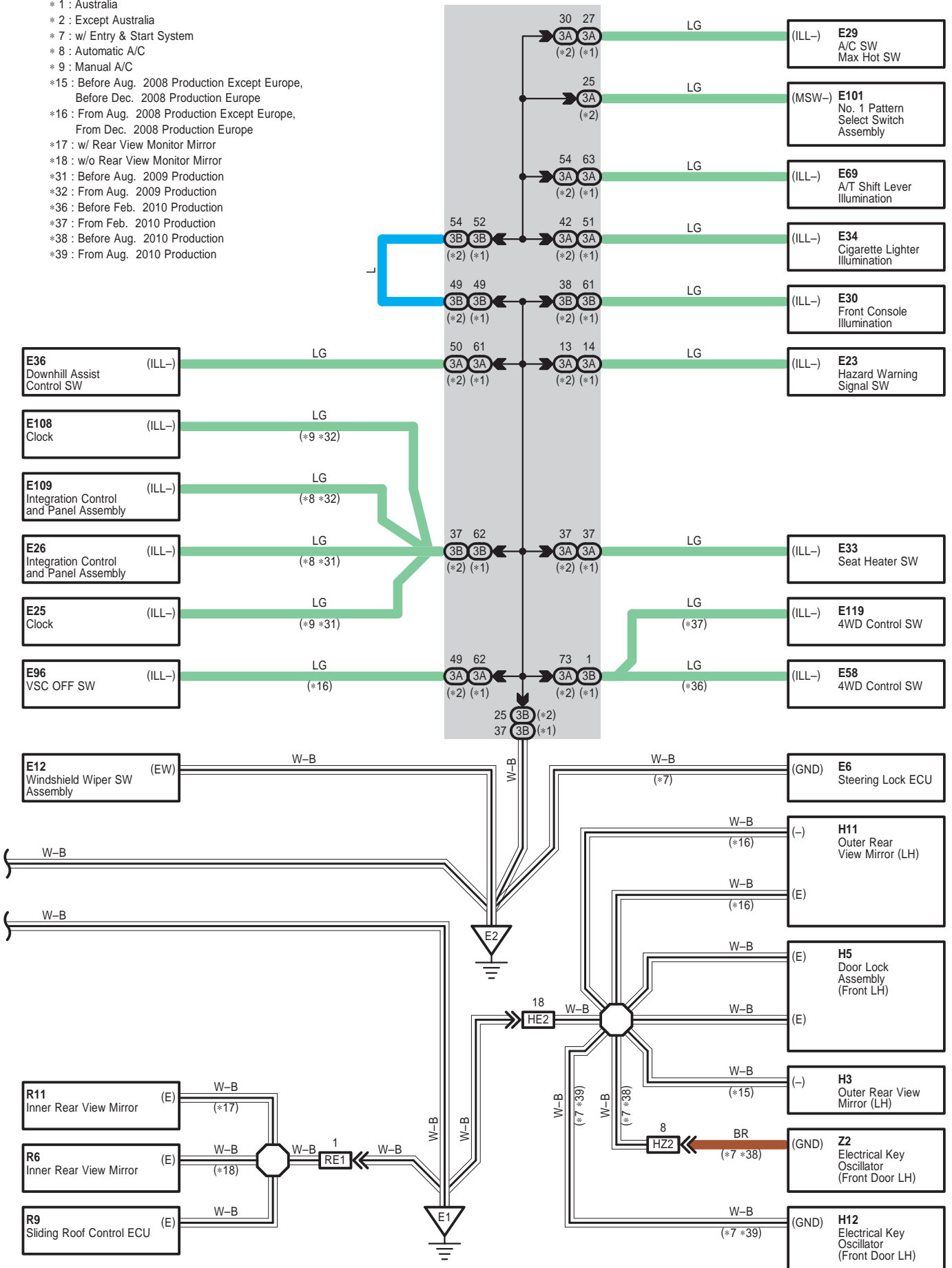

Ground Point <RHD>

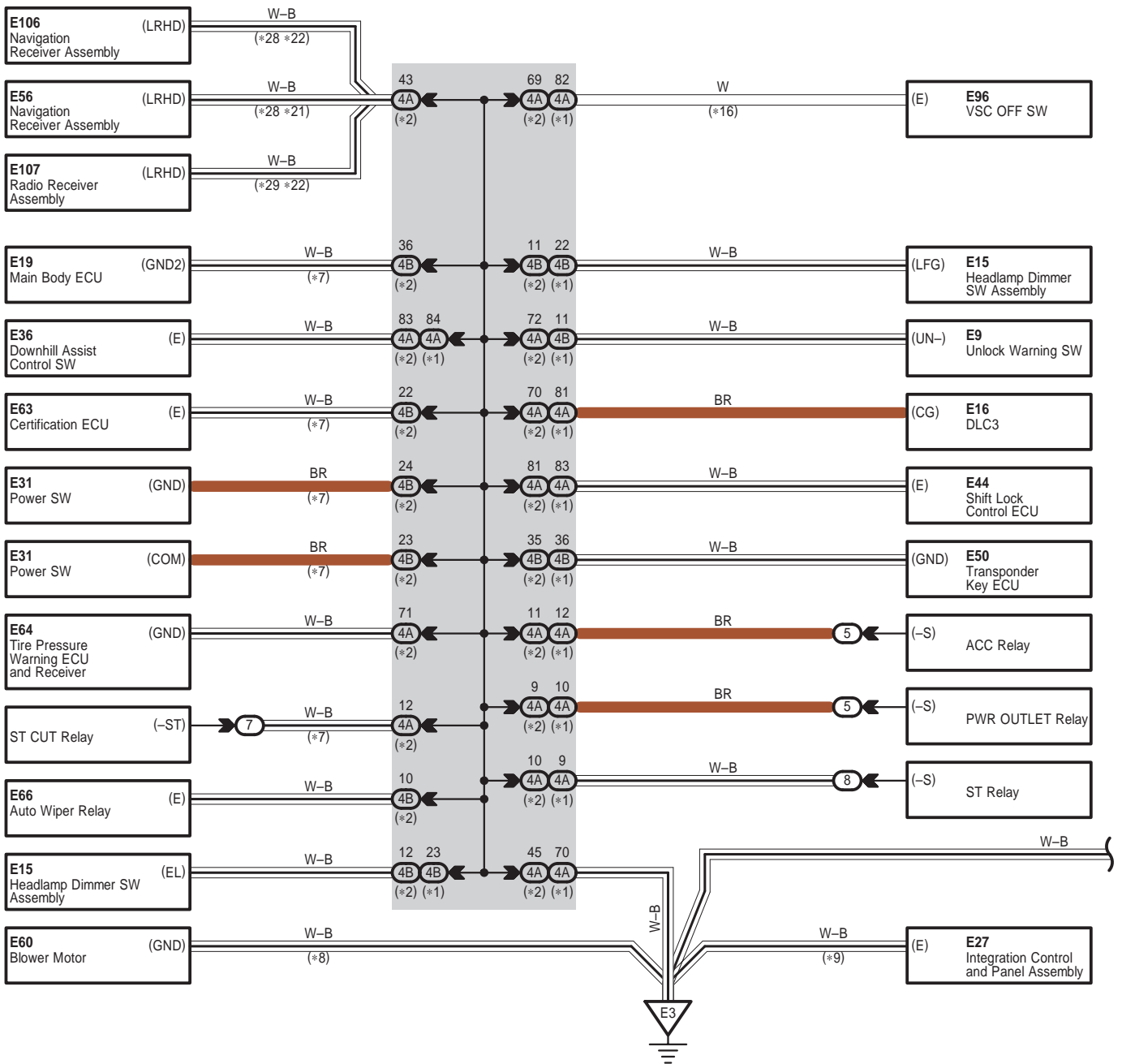

- * 1 : Australia
- * 2 : Except Australia
- * 7 : w/ Entry & Start System
- * 8 : Automatic A/C
- * 9 : Manual A/C
- *10 : Short Body
- *15 : Before Aug. 2008 Production Except Europe,
Before Dec. 2008 Production Europe
- *16 : From Aug. 2008 Production Except Europe,
From Dec. 2008 Production Europe
- *21 : Before Dec. 2008 Production Europe
- *22 : From Dec. 2008 Production Europe
- *27 : Long Body
- *28 : w/ Navigation System (Map Type)
- *29 : w/o Navigation System (Map Type)
- *36 : Before Feb. 2010 Production
- *37 : From Feb. 2010 Production
- *38 : Before Aug. 2010 Production
- *39 : From Aug. 2010 Production

Ground Point <RHD>

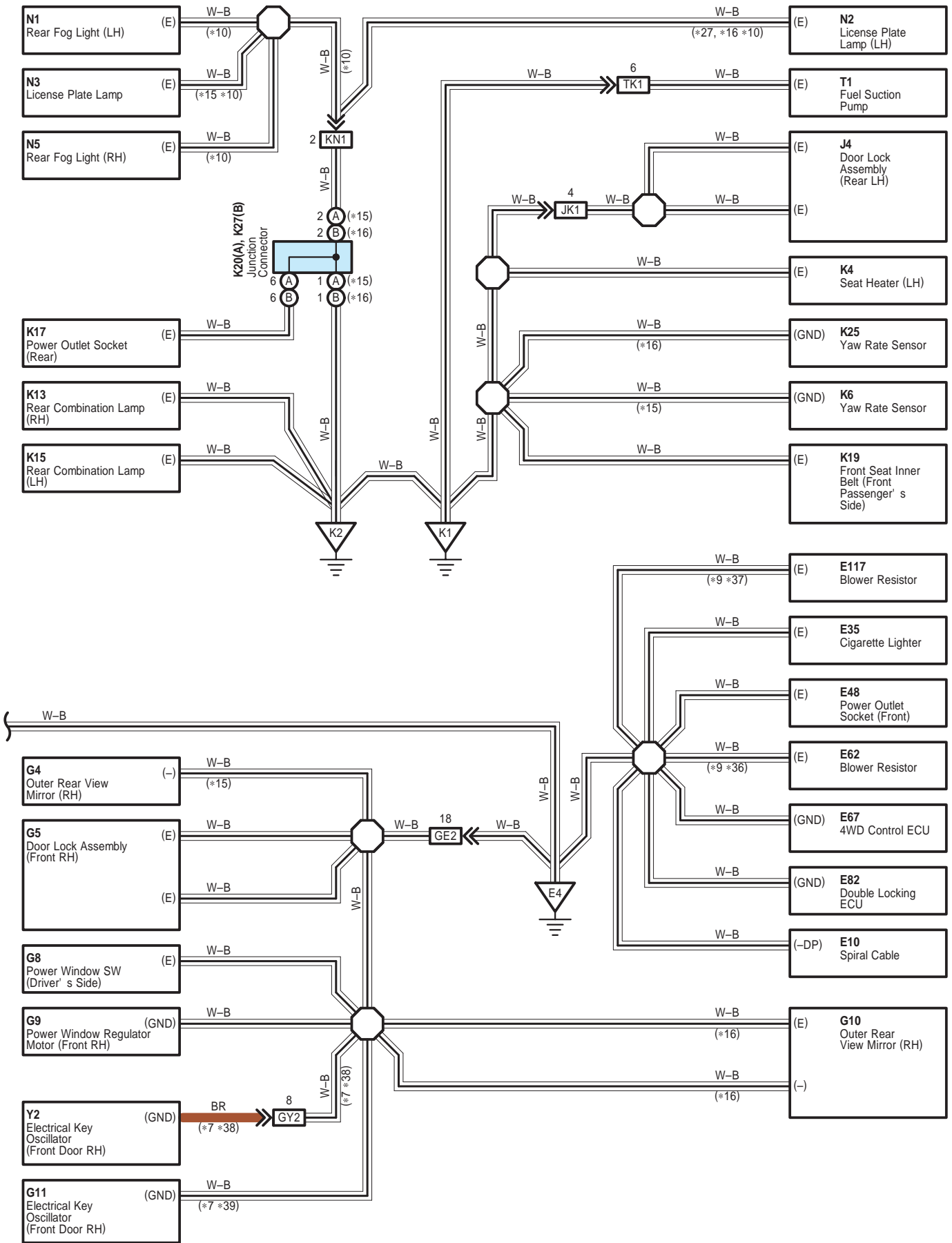

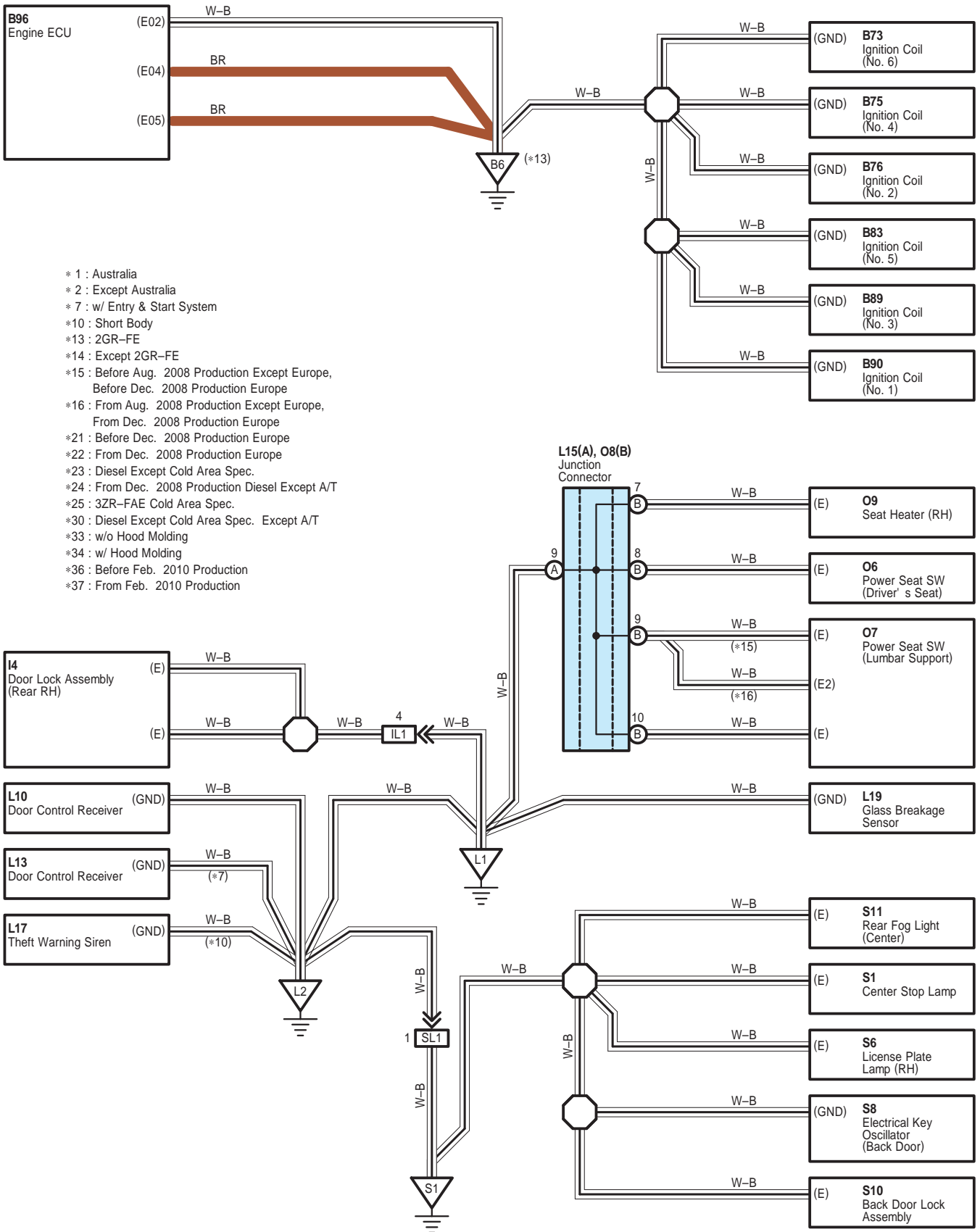

- * 1 : Australia
- * 2 : Except Australia
- * 7 : w/ Entry & Start System
- *10 : Short Body
- *13 : 2GR-FE
- *14 : Except 2GR-FE
- *15 : Before Aug. 2008 Production Except Europe, Before Dec. 2008 Production Europe
- *16 : From Aug. 2008 Production Except Europe, From Dec. 2008 Production Europe
- *21 : Before Dec. 2008 Production Europe
- *22 : From Dec. 2008 Production Europe
- *23 : Diesel Except Cold Area Spec.
- *24 : From Dec. 2008 Production Diesel Except A/T
- *25 : 3ZR-FAE Cold Area Spec.
- *30 : Diesel Except Cold Area Spec. Except A/T
- *33 : w/o Hood Molding
- *34 : w/ Hood Molding
- *36 : Before Feb. 2010 Production
- *37 : From Feb. 2010 Production

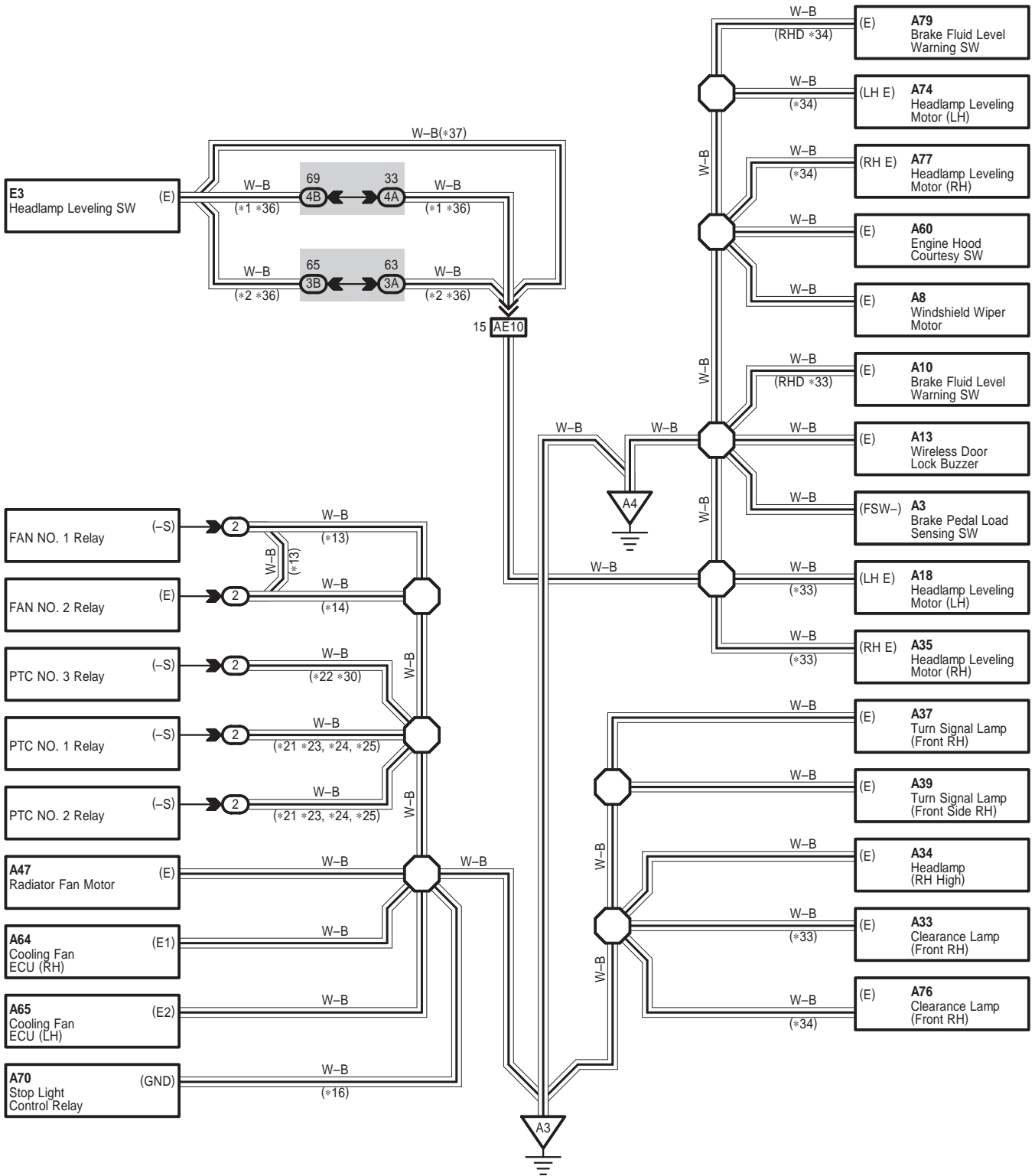

Ground Point <RHD>

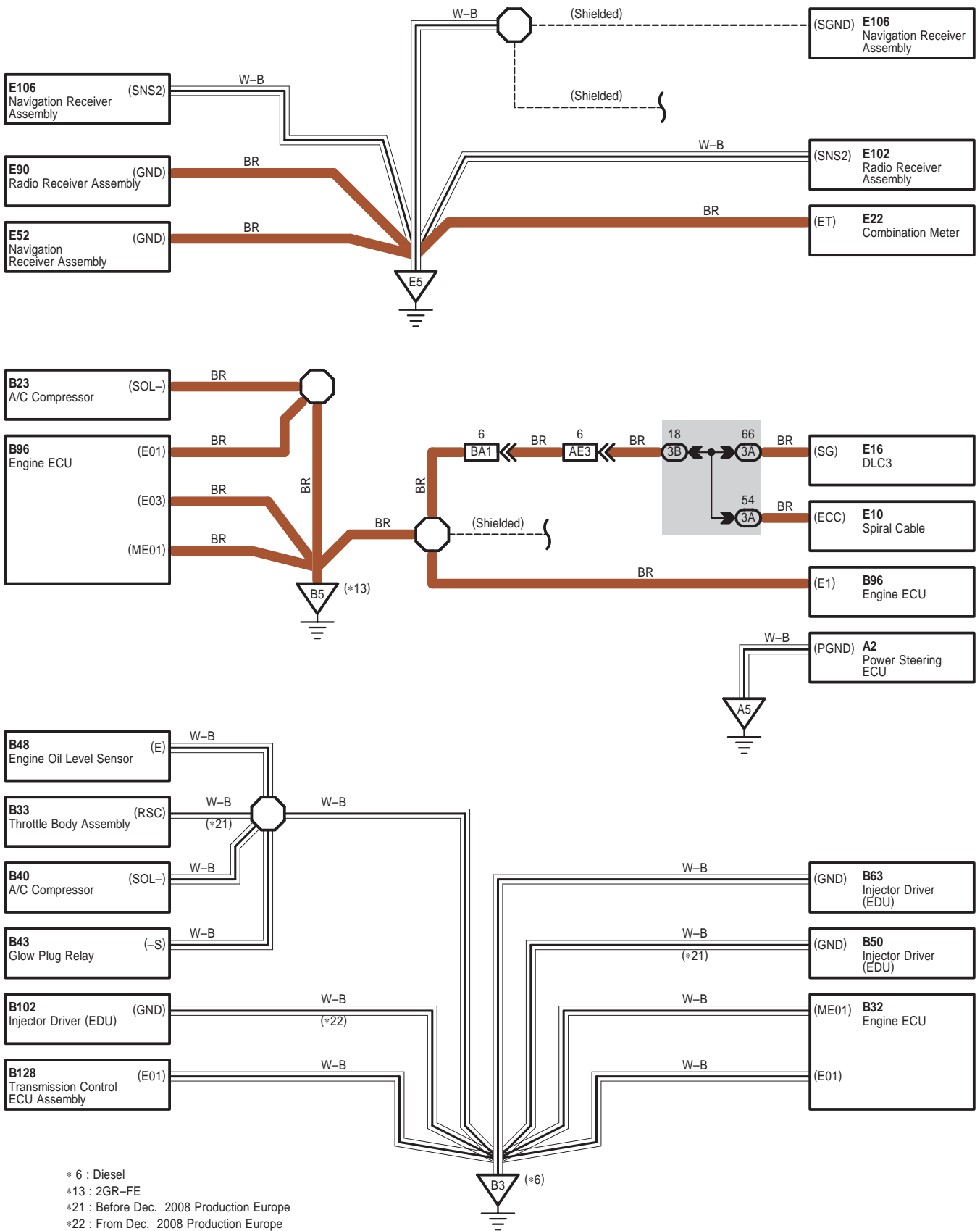

Ground Point <RHD>

A 71
White

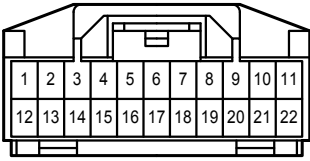

K 20
Black

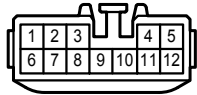

K 27
Gray

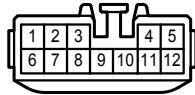

L 15
White

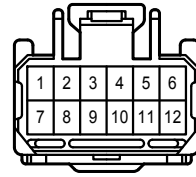

O 8
Gray

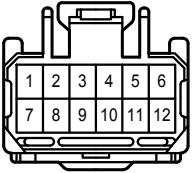

1A
White

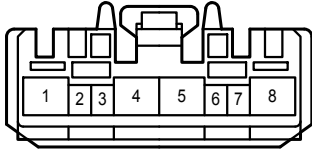

1B
White

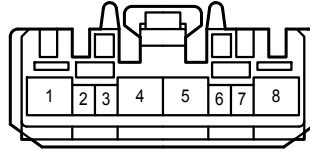

3A
White

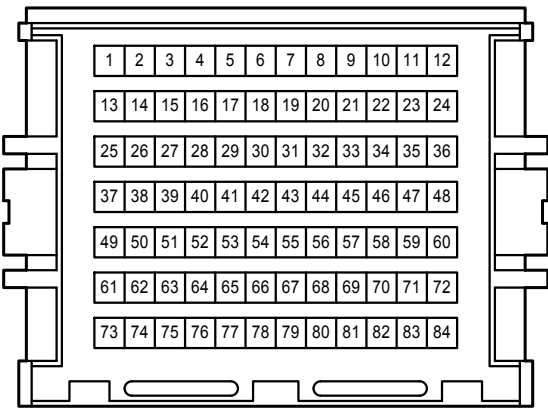

3B
White

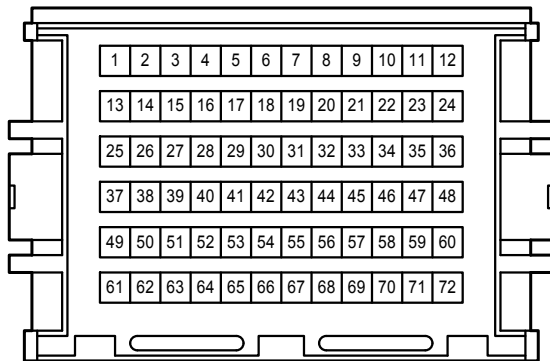

4A
White

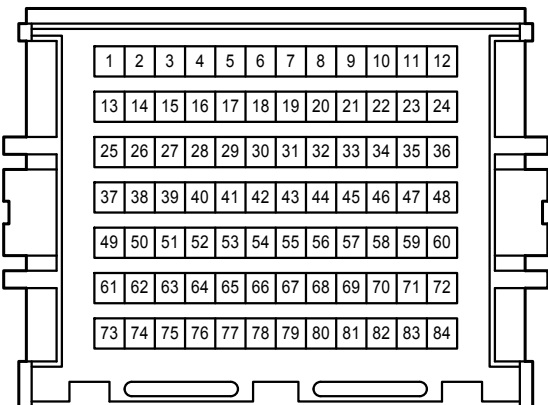

4B
White

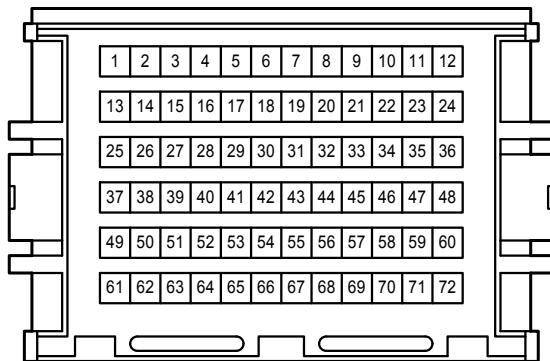

1E
White

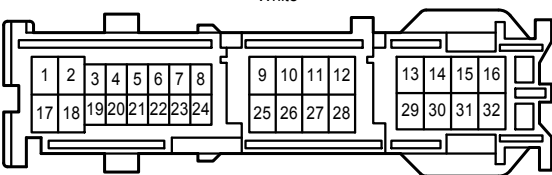

1K
White

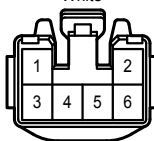

1M
White

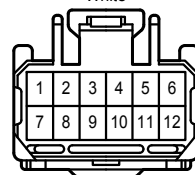

Ground Point <RHD>

